



FrymaKoruma MaxxD

Vacuum processing unit for liquids and semi-solids



Homogenizer



Lid with agitator

Vacuum processing unit for liquids and semi-solids

The MaxxD is designed principally for the food, cosmetic and chemical sectors and is the ideal solution for manufacturing emulsions and suspensions over a wide viscosity range. Highly advanced processing technology offers consistently high product quality with shorter batch cycles, minimal operating costs, low space requirements and simple operation.

With extensive experience at the leading edge of vacuum processing, FrymaKoruma has developed a system that addresses the fundamental requirements of the market, including, flexible process parameters settings and a robust design for demanding production conditions. The systems are easy to upgrade to reflect the latest processing trends.

With its modular structure, the MaxxD can be adapted to the individual needs of the user. The plant can be operated alone or linked into an integrated system. Thanks to a comprehensive range of options, the flexibility of the MaxxD can be expanded. Each available option is completely integrated in the system's operating unit and meets all necessary safety standards.

Many years experience combined with extensive research & development has produced the best combination of vessel and agitation system, offering high productivity, quality and yield. This flexible system allows relatively low minimum batch sizes to be produced. Thanks to the conical structure and proven geometric shape, the vessel has optimal product flow and simple cleaning of all surfaces.

- 1 Product infeed
- 2 Product discharge
- 3 Homogenizer
- 4 Residue discharge
- 5 Agitator
- 6 Vortex breaker
- 7 Vacuum system
- 8 Heating/cooling
- 9 CIP

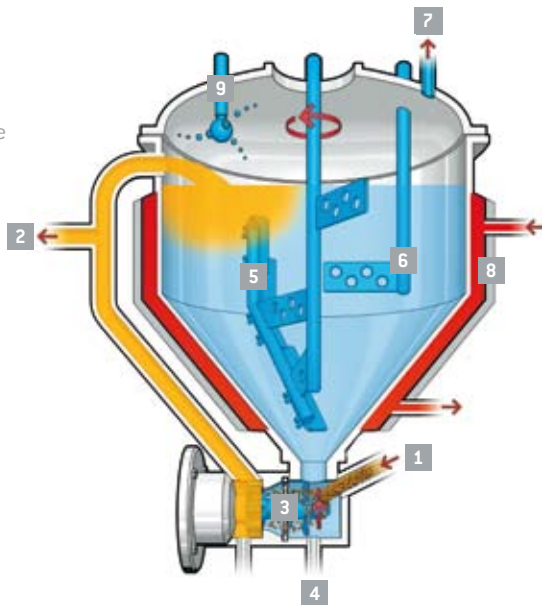

MaxxD



The heart of the MaxxD is the externally mounted homogenizer, which introduces shear, drives product flow and discharges the completed batch.

- ◇ Interchangeable homogeniser tools: toothed rotor-stator or colloid head
- ◇ Aseptic construction
- ◇ Simple to dismantle for maintenance or interchange of tooling
- ◇ No additional pump required for discharging the product or cleaning (unless over 700 litres)

The scraper agitator prevents the product from baking onto the inner wall of the vessel during the heating phases. The integrated vacuum system with its powerful ring vacuum pump pulls both liquid and dry components directly into the homogenizer. The vacuum is fully controllable such that it is perfectly adjusted to each processing stage with «on demand» operation for environmentally friendly, economical production. The vacuum line can be fully flushed for cleaning purposes.

The easy-to-use MaxxD control package can incorporate recipe control for simple and fast set-up. This PLC based package has pre-programmed settings which suit individual application requirements and allows for flexible configuration.



Standard version

- Vessel with agitator
- Homogenization system
- Re-circulation line
- Vacuum system
- User-friendly interface

Options

- Double jacket and insulating jacket for heating/cooling complete with temperature control and safety equipment
- Direct steam injection for accelerated product heating
- Pneumatically activated process valves
- Product feed via flow meter, load cells or dosing units
- Variable speed control of homogenizer
- Sine pump for mixing particulates (e.g. herbs and spices)
- Further options upon request

Applications

- Ketchup, mayonnaise, sauces, dressings
- Emulsions, lotions, creams, gels, shampoo
- Inks, photographic emulsions

Key benefits

- Excellent price-performance ratio
- High production flexibility through replaceable dispersing elements
- Low cost of ownership with few wear parts and excellent accessibility
- Short cleaning times
- Rapid feeding of large quantities of dry materials
- Efficient homogenizer for fast creation of emulsions, significantly reduced production times and lower operating costs
- Programmable process parameters guarantee high reproducibility
- End products are stable, glossy and air free with a consistent specific weight for improved filling performance downstream

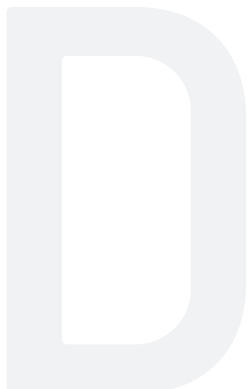

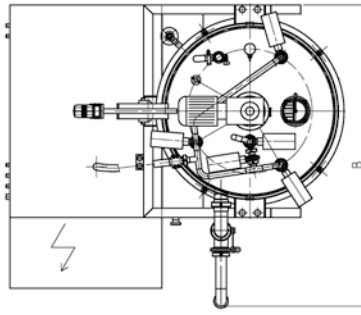
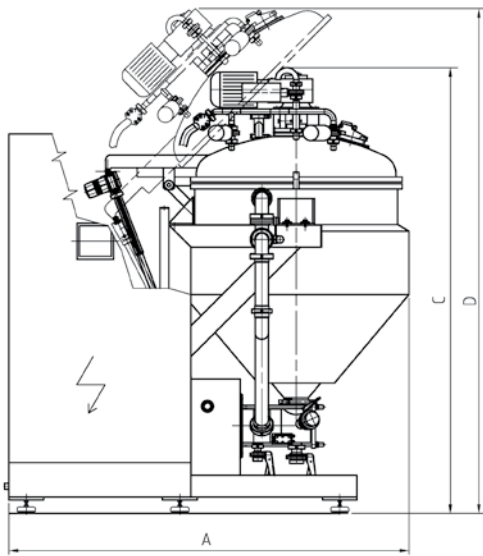

	Usable volume (l)	Installed power (kW), approx.	Dimensions (mm)				Weight (kg), approx.
			Length A	Width B	Height C	Height* D	
MaxxD Lab	12	9	1340	880	1590	1590	450
MaxxD 200	160	22	1900	1500	2140	2200	1000
MaxxD 400	300	22	2050	1700	2320	2500	1200
MaxxD 700	500	22	2250	1900	2700	2900	1800
MaxxD 1300	1100	45.5	3000	2100	3100		3000
MaxxD 1800	1500	45.5	3000	2100	3400		3800

* with open lid

For over 50 years, FrymaKoruma has been a leading international supplier of innovative process solutions for the pharmaceutical, cosmetic, food and chemical industries. Based in Germany and Switzerland, the company employs 200 people. The company's two principal areas of expertise are in one bowl vacuum processing for liquids and crèmes and in milling and grinding of materials from chemical pigments through to food ingredients. With over 23,000 installations worldwide, FrymaKoruma is undoubtedly the leader in its field, consistently setting the standards to which the market aspires. The company's enviable reputation and continuing success are based on the proven high performance and robustness of its equipment together with a desire to exceed customer expectation and build long term relationships. FrymaKoruma is a Romaco

Group company who since 2001 have been part of the NYSE listed corporation Robbins & Myers, Inc. a leading supplier of highly engineered, critical equipment and systems for global energy, chemical and industrial markets.

Customer support

FrymaKoruma understands that the scope of supply embraces much more than technology. Our team of highly skilled engineers work with you to develop a technical specification that exactly matches your requirements. From initial consultation through to installation and commissioning, FrymaKoruma offer a professional turn key solution.

At ProTec, our process technology center, customers have the opportunity to develop and optimize recipes in a modern laboratory, produce test batch-

es, carry out scale-ups or take part in detailed training courses. Our experienced team of process application technologists can guide customers through the development of everything from liquids to semi-solid products.

Our After Sales Service department, provide a comprehensive range of aftermarket products to ensure high availability and longevity for your equipment. Our team of technicians are able to offer on site maintenance and training to ensure high levels of effectiveness from your equipment. Furthermore, modifications and upgrades to plant which reflect changes in your business can be carried out on site. Our spare parts service is customer-orientated. We provide a high availability of spare parts which are promptly dispatched.

Romaco
FrymaKoruma

Sales
FrymaKoruma GmbH
Fischerstraße 13
79395 Neuenburg
Germany
Tel. +49 (0)7631 7067 0
Fax +49 (0)7631 7067 29

Service
FrymaKoruma AG
Theodorshofweg
4310 Rheinfelden
Switzerland
Tel. +41 (0)61 8364 141
Fax +41 (0)61 8364 169

frymakoruma@romaco.com
www.frymakoruma.com

A Unit of Robbins & Myers, Inc.

 **Romaco**
EXCELLENCE THROUGH INNOVATION