



# FrymaKoruma MaxxD Lab

The Unique Lab Scale Vacuum Processing Unit

## The ultimate solution for semi-solids product development and scale up

The FrymaKoruma MaxxD Lab is a lab scale vacuum processing unit for the food and cosmetic industry. The MaxxD Lab is ideal for the development of new recipes from formulation to full production as well as for scale up of a wide range of semi-solid products such as suspensions, crèmes, emulsions, gels, sauces or dressings.

### Key Benefits:

- ◆ reduction of production times up to 60 %
- ◆ highest flexibility for product and process requirements
- ◆ aseptic design for fast and efficient cleaning
- ◆ batch-to-batch consistency and high reproducibility
- ◆ ergonomic operation and handling

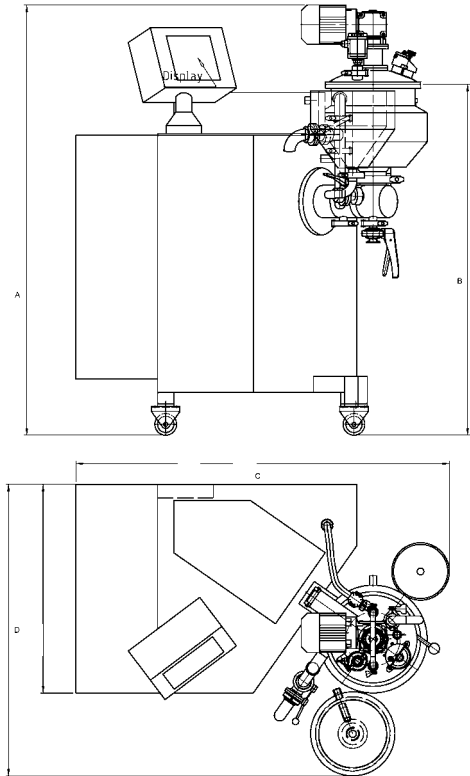

A Unit of Robbins & Myers, Inc.

Processing vessel volume	min. 3 l	max. 12 l	total 15 l	
Pressure resistance	vessel vacuum tight -1 to 0 bar		double jacket pressure tight max. +6 bar	
Product inlet	feed stud with valve	dry ingredients	DN 25	DN 25
		liquid ingredients	DN 25	
Product outlet	circulation pipe with three way valve		DN 40	
Homogenizer	7,5 kW	600 - 5000 rpm / 50 Hz		3 - 26 m/sec
Scraper agitator	0,37 kW	max. 50 rpm / 50 Hz		
Vacuum pump	0,75 kW			
Dimensions (approx.) [mm]	A = 1590	B = 1290	C = 1340	D = 880
Weight (approx.) [kg]	450			

technical data subject to modification

© 2004 Romaco AG

FRY\_4EN\_MX\_LAB\_1104