



FrymaKoruma MaxxD 1800

The Vacuum Processing Unit with exchangeable Homogenizer

Unbeatable batch times at perfect product quality

The FrymaKoruma MaxxD is a vacuum processing unit for the food and cosmetic industry. Due to its wide ranges of features its ideal for the manufacture of different products with a wide variation of processing requirements. It is used for the manufacture of all semi-solid products such as suspensions, emulsions and gels up to a viscosity of 80.000mPas. The exchangeable homogenizer allows to use the perfect tool for each product.

Key Benefits:

- ◆ reduction of production times up to 60 %
- ◆ highest flexibility for product and process requirements
- ◆ aseptic design for fast and efficient cleaning
- ◆ batch-to-batch consistency and high reproducibility
- ◆ ergonomic operation and handling
- ◆ perfect deaeration of the product

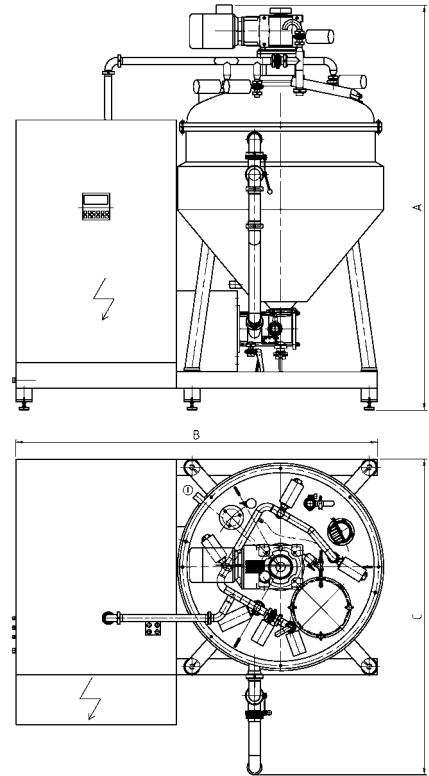

A Unit of Robbins & Myers, Inc.

Processing vessel volume	min. 220 l	max. 1500 l	total 1800 l
Pressure resistance	vessel vacuum tight -1 to 0 bar		double jacket pressure tight max. +6 bar
Product inlet	feed stud with valve	dry ingredients liquid ingredients	DN 50 DN 50
Product outlet	circulation pipe with three way valve		DN 80
Homogenizer	37 kW	600 - 3000 rpm / 50 Hz	6 – 28 m/sec
Scraper agitator	5,5 kW	max. 25 rpm / 50 Hz	
Vacuum pump	2,2 kW		
Dimensions (approx.) [mm]	A = 3400	B = 3000	C = 2100
Weight (approx.) [kg]	3800		

technical data subject to modification

© 2004 Romaco AG

FRY_4EN_MX 1800_1104