



FrymaKoruma Dinex Lab

The Unique Lab Scale Vacuum Processing Unit

The ultimate solution for semi-solids product development and scale up

The FrymaKoruma Dinex Lab is a laboratory-scale version of the high-performance Dinex vacuum processing unit, used principally in the pharmaceutical and cosmetics industry. The Dinex Lab is ideal for the development of new recipes from formulation to full production as well as for scale up of a wide range of semi-solid products such as suspensions, cremes, emulsions and gels.

Key Benefits:

- ◆ internal and external homogenization offers process flexibility and a wide batch size range
- ◆ adjustable stator ensures gentle processing for sensitive products at low shear force
- ◆ highest flexibility for product and processing requirements
- ◆ homogenizer doubles as a pump – for pumping over or CIP: no additional pump required
- ◆ batch-to-batch consistency and compatibility with scale up procedures
- ◆ ergonomic operation and handling

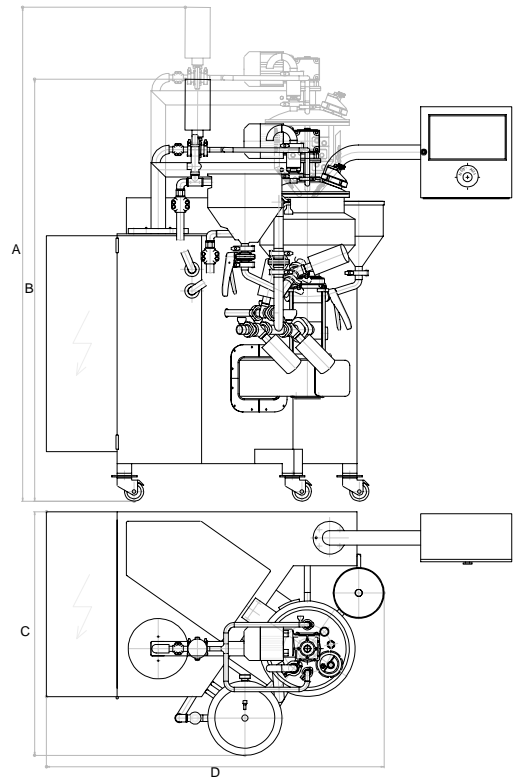

A Unit of Robbins & Myers, Inc.

Processing vessel volume	min. 3 l	max. 12 l	total 15 l	
Pressure resistance	vessel vacuum tight –1 to 0 bar		double jacket pressure tight max. +6 bar	
Product inlet	feed stud with valve	dry ingredients liquid ingredients	DN 25 DN 25	
Product outlet	circulation pipe with three way valve		DN 40	
Homogenizer	7,5 kW	1000 - 5000 rpm / 50 Hz	3 – 26 m/sec	
Scraper agitator	0,37 kW	max. 50 rpm / 50 Hz		
Vacuum pump	0,75 kW			
Dimensions (approx.) [mm]	A = 2100	B = 1810	C = 1015	D = 1410
Weight (approx.) [kg]	650			

technical data subject to modification

© 2004 Romaco AG

FRY_4EN_DX_LAB_1104