



FrymaKoruma Dinex 5200

State of the Art Vacuum Processing

The high performance vacuum processing unit for the manufacture of semi-solids

The FrymaKoruma Dinex is a vacuum processing unit for the pharmaceutical and cosmetic industry. Due to its wide ranges of features its ideal for the manufacture of different products with a wide variation of processing requirements. All semi-solid products such as suspensions, crèmes, emulsions, and gels can be reliably manufactured in a fast and efficient way. Even a sterile version of the Dinex is available.

Key Benefits:

- ◆ internal and external homogenization offers process flexibility and a wide batch size range
- ◆ adjustable stator ensures gentle processing for sensitive products at low shear force
- ◆ highest flexibility for product and process requirements
- ◆ homogenizer doubles as a pump – for pumping over or CIP: no additional pump required
- ◆ batch-to-batch consistency and compatibility with scale up procedures
- ◆ ergonomic operation and handling

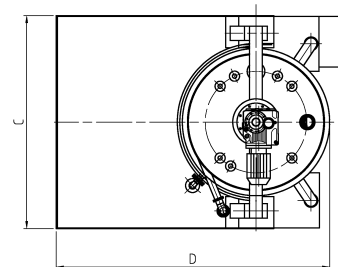
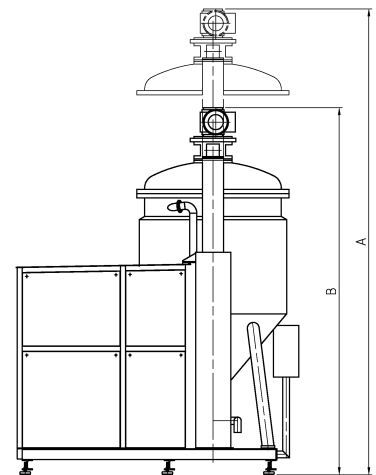

A Unit of Robbins & Myers, Inc.

technical data subject to modification

© 2004 Romaco AG

FRY_4EN_DX 5300_1104

Processing vessel volume	min. 200 l	max. 4000 l	total 5200 l	
Pressure resistance	vessel vacuum tight –1 to 0 bar		double jacket pressure tight max. +6 bar	
Product inlet	feed stud with valve	dry ingredients	DN -	DN -
		liquid ingredients		
Product outlet	circulation pipe with three way valve		DN -	
Homogenizer	45 kW	600 - 3000 rpm / 50 Hz	7 – 36 m/sec	
Scraper agitator	- kW	max. - rpm / 50 Hz		
Vacuum pump [kW]	5,5			
Dimensions (approx.) [mm]	A = -	B = 5100	C = 3000	D = 3350
Weight (approx.) [kg]	15'000			

Processing Division • Romaco FrymaKoruma

FrymaKoruma GmbH • Fischerstrasse 13 • 79395 Neuenburg • Germany

Phone +49 (0)7631 7067 0 • Fax +49 (0)7631 7067 29 • frymakoruma@romaco.com • www.romaco.com