



FrymaKoruma Dinex 85

State of the Art Vacuum Processing

The high performance vacuum processing unit for the manufacture of semi-solids

The FrymaKoruma Dinex is a vacuum processing unit for the pharmaceutical and cosmetic industry. Due to its wide ranges of features its ideal for the manufacture of different products with a wide variation of processing requirements. All semi-solid products such as suspensions, crèmes, emulsions, and gels can be reliably manufactured in a fast and efficient way. Even a sterile version of the Dinex is available.

Key Benefits:

- ◆ internal and external homogenization offers process flexibility and a wide batch size range
- ◆ adjustable stator ensures gentle processing for sensitive products at low shear force
- ◆ highest flexibility for product and process requirements
- ◆ homogenizer doubles as a pump – for pumping over or CIP: no additional pump required
- ◆ batch-to-batch consistency and compatibility with scale up procedures
- ◆ ergonomic operation and handling

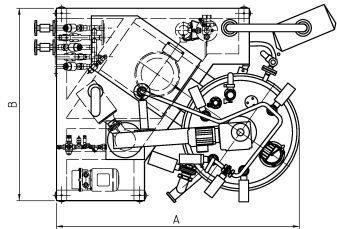
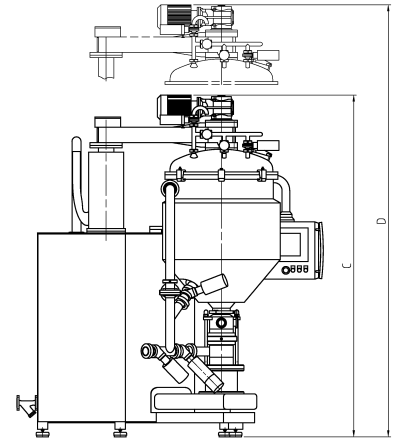

A Unit of Robbins & Myers, Inc.

Processing vessel volume	min. 8 l	max. 60 l	total 85 l	
Pressure resistance	vessel vacuum tight –1 to 0 bar		double jacket pressure tight max. +6 bar	
Product inlet	feed stud with valve	dry ingredients liquid ingredients	DN 50 DN 50	
Product outlet	circulation pipe with three way valve		DN 65	
Homogenizer	7,5 kW	600 - 3000 rpm / 50 Hz		5 – 25 m/sec
Scraper agitator	0,75 kW	max. 50 rpm / 50 Hz		
Vacuum pump	1,5 kW			
Dimensions (approx.) [mm]	A = 2300	B = 1850	C = 1150	D = 1500
Weight (approx.) [kg]	1100			

technical data subject to modification

© 2008 Romaco AG

FRY_4EN_DX 0085_0308