



FrymaKoruma



FrymaKoruma Dinex

Vacuum processing unit for liquids and semi-solids



Homogenizer (sterile version)



Dinex Lab

Vacuum processing unit for liquids and semi-solids

The Dinex vacuum processing unit from FrymaKoruma is used for the production of emulsions and suspensions for pharmaceuticals and premium cosmetics over a wide viscosity range. Advanced processing technology offers consistently high product quality, shorter batch cycles, minimal operating costs, low space requirements and simple operation.

With extensive experience at the leading edge of vacuum processing, FrymaKoruma has developed a system that addresses the fundamental requirements of the market, including, flexible process parameters settings and a robust design for demanding production conditions. The systems are easy to upgrade to reflect the latest processing trends.

With its modular structure, the Dinex can be adapted to the individual needs of the user. The plant can be operated alone or linked into an integrated system. Thanks to a comprehensive range of options, the flexibility of the Dinex can be expanded. Each available option is completely integrated in the system's operating unit and meets all necessary safety standards.

Many years experience combined with extensive research & development has produced the best combination of vessel and agitation system, offering high productivity, quality and yield.

This flexible system allows relatively low minimum batch sizes to be produced. Thanks to the conical structure and proven geometric shape, the vessel has optimal product flow and simple cleaning of all surfaces.



Dinex

The heart of the Dinex is the externally mounted homogenizer, which introduces shear, drives product flow and discharges the completed batch.

- ◇ Vertical homogenizer
- ◇ Aseptic construction
- ◇ Adjustable shearing gap
- ◇ No additional pump required for discharging the product or cleaning (unless over 700 litres)

The integrated vacuum system with its powerful ring vacuum pump pulls both liquid and dry components directly into the homogenizer. The vacuum is fully controllable such that it is perfectly adjusted to each processing stage with «on demand» operation for environmentally friendly, economical production. The vacuum line can be fully flushed for cleaning purposes.

The easy-to-use Dinex control package can incorporate recipe control for simple and fast set-up. This PLC based package has pre-programmed settings which suit individual application requirements and allows for flexible configuration.

- 1 Product infeed
- 2 Product discharge
- 3 Homogenizer
- 4 Residue discharge
- 5 Scraper agitator
- 6 Counter rotating agitator
- 7 Vacuum system
- 8 Heating/cooling
- 9 CIP
- 10 Short loop
- 11 Long loop
- 12 Stator adjustment

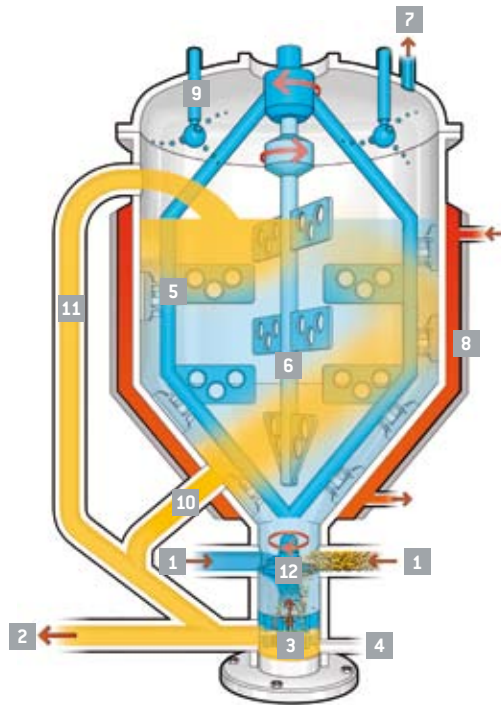

Key benefits

- Programmable process parameters guarantee high reproducibility
- Highly efficient processing for significantly reduced batch times and operating costs
- End products are stable, glossy and air free with a consistent specific weight for improved filling performance downstream
- Rapid feeding of large quantities of dry materials
- Large variability in batch sizes
- Shear energy optimisation by means of stator adjustment
- High transfer performance in pump mode

Standard version

- Vessel with agitator
- Vertical homogenizer
- Internal and external homogenisation
- Heating/cooling system with temperature control and safety equipment
- Vacuum system
- User-friendly interface

Options

- Horizontal homogenizer
- Coaxial agitator: counter rotating scraper/ central agitator
- Choice of automation packages
- Pressure-resistant execution
- Various feed hoppers
- Load cells and dosing units
- ATEX/US-EX
- Further options upon request

Applications

- Lotions, creams, gels, ointments
- Sterile eye drops
- Inhalation liquid
- Toothpaste
- Mascara
- Make-up
- Hair care products



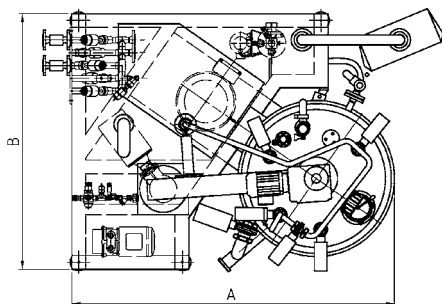
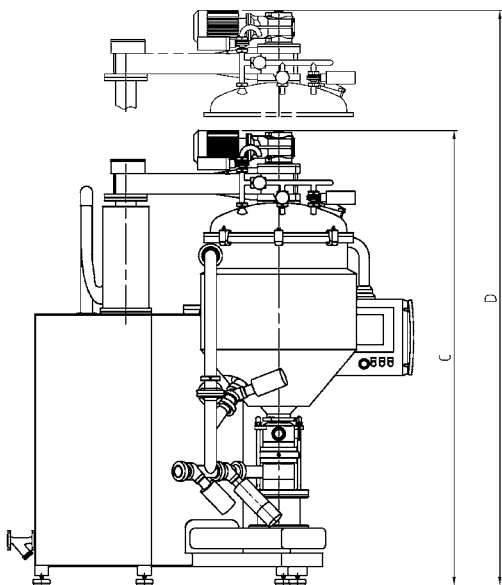

	Usable volume (l)	Installed power (kW), approx.	Dimensions (mm)				Weight (kg), approx.
			Length A	Width B	Height C	Height* D	
Dinex Lab	3–12	9	1410	1015	1810	2100	700
Dinex 85	8–60	11	1500	1150	1850	2300	1100
Dinex 200	15–160	26	2000	1500	2400	3000	1700
Dinex 400	15–300	26	2000	1500	2700	3400	1900
Dinex 700	15–500	34.5	2400	1500	3000	3900	2800
Dinex 1300	50–1100	53.5	2400	1500	3600	4800	3800
Dinex 2400	50–2000	58	3000	2000	4000	5000	6500
Dinex 3500	100–3000	61.5	3300	2500	4900		7000
Dinex 4200	100–3500	71.5	3300	2500	5100		10000
Dinex 5200	200–4000	71.5	3350	3000	5100		15000

* with open lid

For over 50 years, FrymaKoruma has been a leading international supplier of innovative process solutions for the pharmaceutical, cosmetic, food and chemical industries. Based in Germany and Switzerland, the company employs 200 people. The company's two principal areas of expertise are in one bowl vacuum processing for liquids and crèmes and in milling and grinding of materials from chemical pigments through to food ingredients. With over 23,000 installations worldwide, FrymaKoruma is undoubtedly the leader in its field, consistently setting the standards to which the market aspires. The company's enviable reputation and continuing success are based on the proven high performance and robustness of its equipment together with a desire to exceed customer expectation and build long term relationships. FrymaKoruma is a Romaco

Group company who since 2001 have been part of the NYSE listed corporation Robbins & Myers, Inc. a leading supplier of highly engineered, critical equipment and systems for global energy, chemical and industrial markets.

Customer support

FrymaKoruma understands that the scope of supply embraces much more than technology. Our team of highly skilled engineers work with you to develop a technical specification that exactly matches your requirements. From initial consultation through to installation and commissioning, FrymaKoruma offer a professional turn key solution.

At ProTec, our process technology center, customers have the opportunity to develop and optimize recipes in a modern laboratory, produce test batch-

es, carry out scale-ups or take part in detailed training courses. Our experienced team of process application technologists can guide customers through the development of everything from liquids to semi-solid products.

Our After Sales Service department, provide a comprehensive range of aftermarket products to ensure high availability and longevity for your equipment. Our team of technicians are able to offer on site maintenance and training to ensure high levels of effectiveness from your equipment. Furthermore, modifications and upgrades to plant which reflect changes in your business can be carried out on site. Our spare parts service is customer-orientated. We provide a high availability of spare parts which are promptly dispatched.

Romaco
FrymaKoruma

Sales
FrymaKoruma GmbH
Fischerstraße 13
79395 Neuenburg
Germany
Tel. +49 (0)7631 7067 0
Fax +49 (0)7631 7067 29

Service
FrymaKoruma AG
Theodorshofweg
4310 Rheinfelden
Switzerland
Tel. +41 (0)61 8364 141
Fax +41 (0)61 8364 169

frymakoruma@romaco.com
www.frymakoruma.com

A Unit of Robbins & Myers, Inc.

