

intersystems

Model HD-PRT Sampler Manual

Safety

Installation

Operation

Maintenance

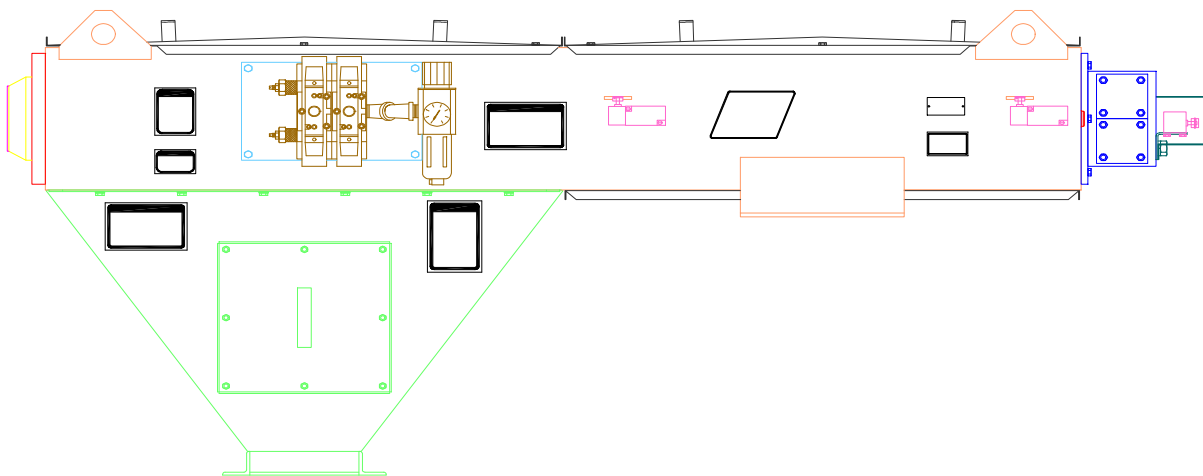

Table of Contents

I. GENERAL SAFETY INFORMATION	3
II. GENERAL INFORMATION	5
2.1 System Description	5
2.2 Optional Features	6
2.3 Material Sampled	6
2.4 Sampler Construction	6
III. GENERAL INSTALLATION REQUIREMENTS	7
3.1 Receiving Inspection	7
3.2 Pre-Installation Preparation	7
3.3 Location	7
3.4 General Mounting Guidelines	8
3.4.1 Sampler Without Optional Mounting Accessories	8
3.4.2 Field-Mounted Sampler Using Weld-On Plate	9
3.5 Material Sample Transport Lines	9
3.6 Controller Location	10
3.7 System Wiring	10
3.7.1 Electrical Power Requirements, System	10
3.7.1.1 Controller	10
3.7.1.2 Solenoid Valve Coil	10
3.8 System Piping	11
3.8.1 Compressed Air Consumption	12
IV. OPERATIONS AND ADJUSTMENTS	13
4.1 Control Components And Their Functions	13
4.1.1 POWER OFF/ON Switch S-2	14
4.1.2 SAMPLING MODE Switch S-3 (Automatic/Manual)	14
4.1.3 MANUAL SAMPLING Switch S-4	14
4.1.4 POWER Pilot Light	14
4.1.5 SAMPLING Pilot Light	14
4.1.6 Digital Display Timer T-1 (Standard)	14
4.1.7 Digital Display Counter C-1 (Optional)	15
4.1.8 Probe Jam Timer T-2	16
4.1.9 Main Fuse	17
4.1.10 Terminal Strip	17
4.2 Sampler Mounted Electrical Components	17
4.2.1 Sample Probe EXTENDED Limit Switch, LS-1	17
4.2.2 Sample Probe RETRACTED Limit Switch, LS-2 (actuated at rest)	17
4.2.3 Sample Probe @ SIX O'CLOCK Limit Switch, LS-3 (actuated at rest)	17
4.2.4 Sample Probe @ THREE O'CLOCK Limit Switch, LS-4	17
4.3 Pneumatic Components	18
4.3.1 Solenoid Valves V-1 And V-2	18
4.3.1.1 Sample Probe EXTEND/RETRACT Valve V-1	18
4.3.1.2 Sample Probe ROTATE Valve V-2	18
4.3.2 Rotation Speed Controls	19
4.3.3 Probe Extend/Retract Speed Control Valve Adjustment	19
4.3.4 Air Filter/Pressure Regulator	19
4.3.5 Pneumatic Cylinders	20
4.3.6 Rotary Actuator	20
4.4 Shock Absorbers	20
V. MAINTENANCE AND REPAIR	21
5.1 General Maintenance	21
5.2 Periodic Inspection	21

5.3 Lubrication	21
5.3.1 Guide Bushings and Drive Bearings	21
5.3.2 Airline Lubricator	22
5.4 Draining and Servicing the Filter	22
5.5 Rotation Reversal	23
VI. TROUBLESHOOTING	24
6.1 General HD-PRT Sampler Troubleshooting	24
6.2 Directional Solenoid Valve Troubleshooting	26
6.3 Air Components Troubleshooting	27
6.3.1 Cylinder Leaking	27
6.3.2 Valve vs. Cylinder Leak Test	28
VII. REPLACEMENT PARTS	29
7.1 Scope	29
7.2 Ordering Parts	29
7.3 Replacement Parts	29
7.4 Repair Kits	30
7.4.1 Sampler Parts Listing HD-PRT w/ 5.50" dia Probe (see Figures 7-1 & 7-2).....	32
7.4.1 Sampler Parts Listing HD-PRT w/ 5.50" dia Probe (see Figures 7-1 & 7-2).....	33
7.4.2 Sampler Parts Listing HD-PRT w/ 8.50" dia Probe (see Figures 7-3 & 7-4).....	36
7.4.2 Sampler Parts Listing HD-PRT w/ 8.50" dia Probe (see Figures 7-3 & 7-4).....	37
VIII. WARRANTY	40

List Of Illustrations & Drawings

FIGURE 1-1, HD-PRT SAMPLER SAFETY LABEL LOCATIONS	4
FIGURE 2-1, TYPICAL INSTALLATION, MODEL HD-PRT SAMPLING SYSTEM	5
FIGURE 3-1, PNEUMATIC SCHEMATIC.....	11
FIGURE 4-1, STANDARD NEMA 4 CONTROL PANEL DETAIL.....	13
FIGURE 4-2, SOLENOID VALVE.....	18
FIGURE 4-3, FILTER/REGULATOR	20
FIGURE 6-1, CONDENSED MOISTURE BLOCKING AIRLINE	26
FIGURE 6-2, VALVE VS. CYLINDER LEAK TEST DIAGRAM	28
FIGURE 7-1, HD-PRT SAMPLER w/ 5.5 od PROBE (TOP & SIDE VIEWS).....	34
FIGURE 7-2, HD-PRT SAMPLER w/ 5.5 od PROBE (END & SECTION VIEWS).....	35
FIGURE 7-3, HD-PRT SAMPLER w/ 8.5 od PROBE (TOP & SIDE VIEWS).....	38
FIGURE 7-4, HD-PRT SAMPLER w/ 8.5 od PROBE (END & SECTION VIEWS).....	39

I. GENERAL SAFETY INFORMATION

SAFETY FIRST! The symbols shown identify examples of the safety labels and signs to be found on Intersystems equipment. They are affixed to the equipment to warn of danger to persons and of possible equipment damage. These signs must never be removed, tampered with, painted over or obscured in any way. (See Page 4 for label locations.) If labels are damaged or become unreadable, replacement labels are available from Intersystems. The user must institute a continuing program to instruct all personnel in safe operating and maintenance procedures, and to insure that all safety devices, guards, and covers are intact and operable, and that all safety signs are legible.

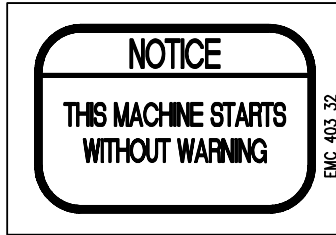

STARTS W/OUT WARNING
EMC40332



MOVING PART
EMC3032

Consult Intersystems before making any changes to the sampler or its operating environment. Careless changes could result in death or serious injury to people, and reduce the performance and service life of the equipment.

Never perform any service on this equipment or any other powered equipment until all power has been shut off and locked out so that it cannot be restored without the consent and knowledge of the person who interrupted power. Power includes electrical, fluid, mechanical, or pneumatic energy.

Never perform any service on this equipment without utilizing the required PPE (personal protective equipment). Refer to the MSDS(s), material safety data sheet(s), on all the products to which this equipment is in contact with to determine what PPE is required.

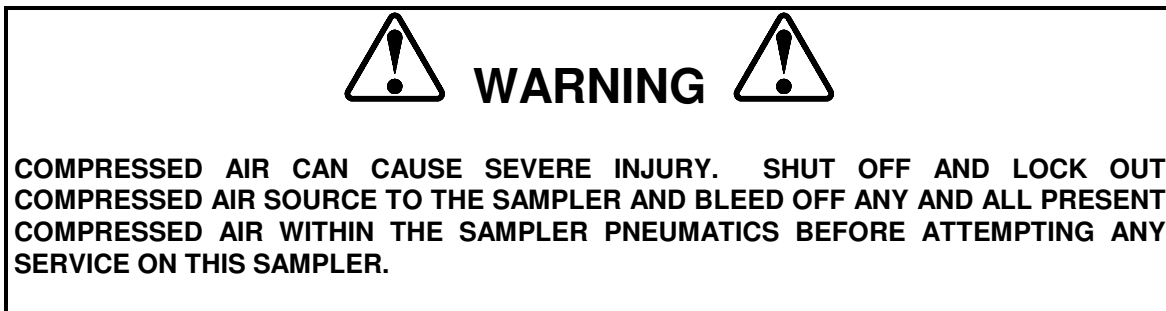
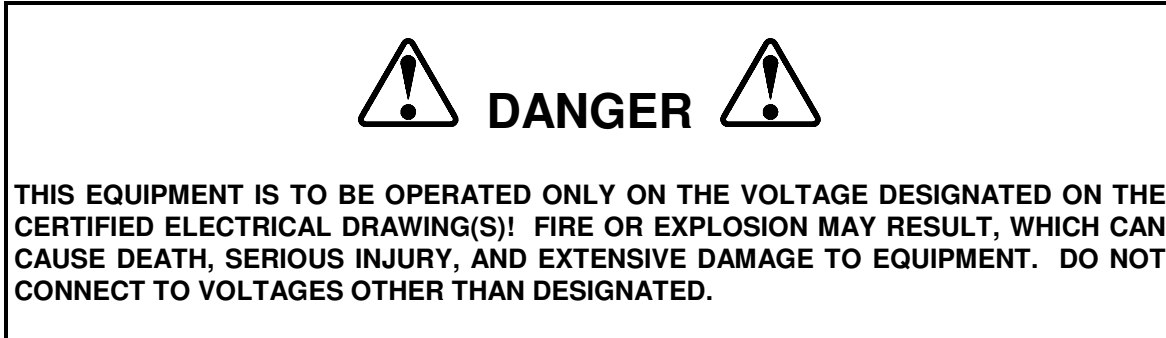

NOTE: THESE SIGNS MUST NEVER BE REMOVED, TAMPERED WITH, PAINTED OVER, OR OBSCURED IN ANY WAY. IF LABELS ARE DAMAGED OR BECOME UNREADABLE, REPLACEMENT LABELS ARE AVAILABLE FROM INTERSYSTEMS.

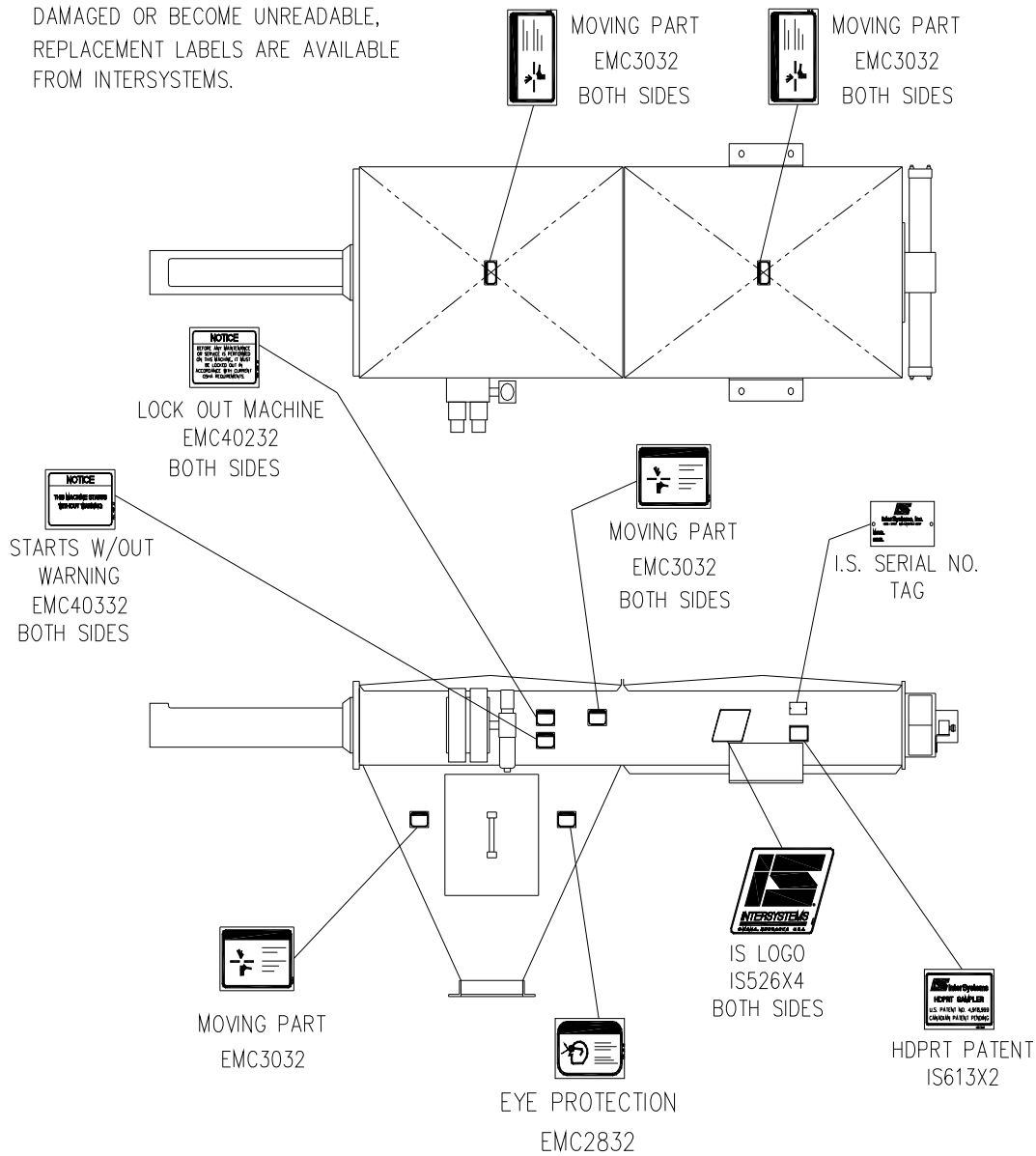

DATE: 8/16/94

FIGURE 1-1, HD-PRT SAMPLER SAFETY LABEL LOCATIONS

II. GENERAL INFORMATION

2.1 System Description

The HD-PRT Sampler is designed to collect a representative sample of granular, pellet, chip, flake or other materials in a gravity chute or from a conveyor discharge. Figure 2-1 illustrates a typical HD-PRT Sampler application.

Sample collection is initiated in response to either an operator's manual command or a signal automatically generated by controller logic. A sample cycle begins when a pair of double-acting pneumatic cylinders extend the slotted sampling probe into the product stream. Then the rotary actuator rotates the sample probe clockwise (when viewed from the rotary actuator end of the sampler) through a 270° arc, exposing the sample probe cavity to the product stream to collect a sample of the material. Next, the cylinders retract the sample probe from the product stream, isolating the sample and sample probe cavity from the product stream. Subsequently, the rotary actuator rotates the sample probe counter-clockwise through 270°, dumping the collected sample into the sampler's discharge chute. The sample then falls down and out of the discharge chute to the desired sample collection point, at which point an InterSystems SCS Sample Collection System (optional) may be installed.

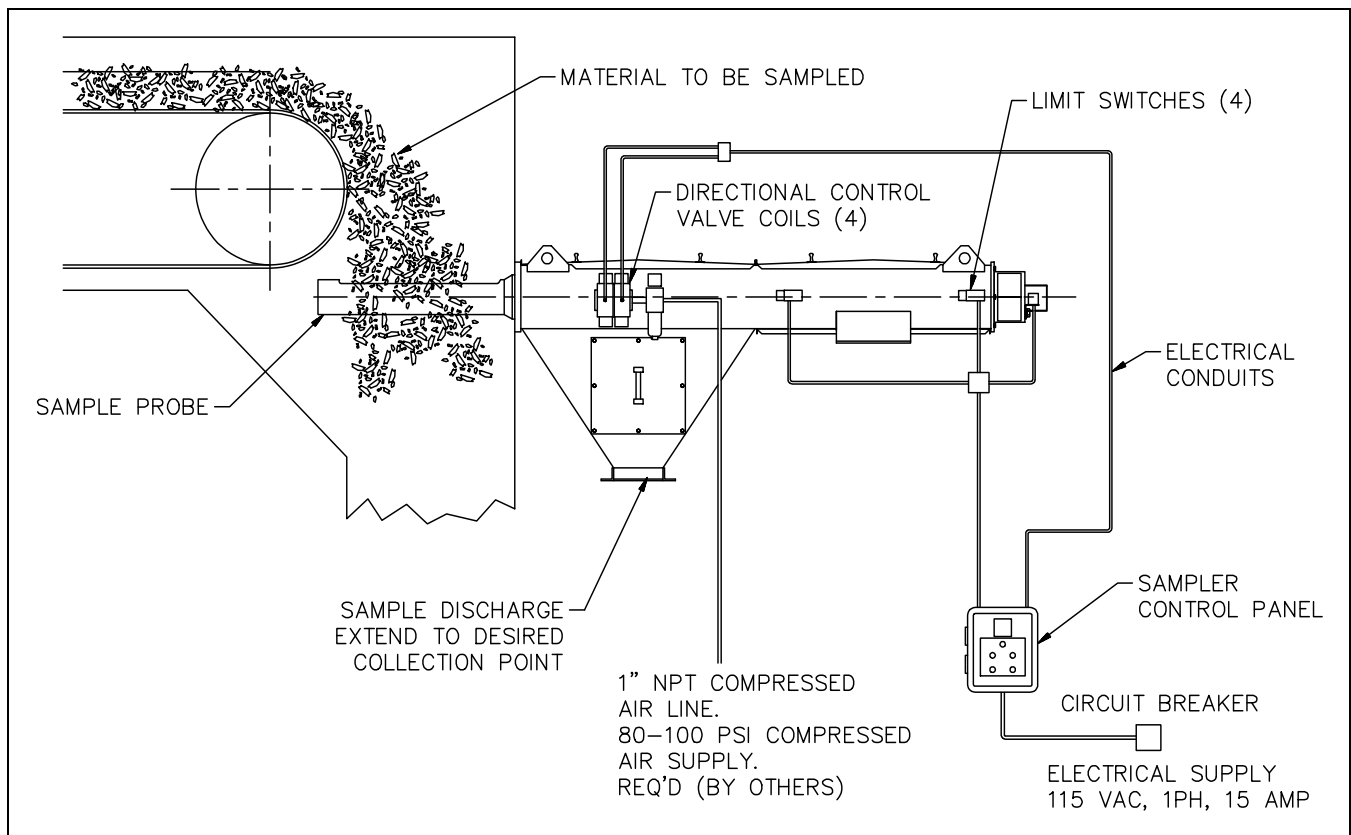

FIGURE 2-1, TYPICAL INSTALLATION, MODEL HD-PRT SAMPLING SYSTEM

2.2 Optional Features

The certified drawings indicate which, if any, optional features are included with a sampling system. Some of the more frequently specified optional features are briefly described in the following list.

- A. Controller arranged to initiate a sampling cycle based on quantity or volume of material passing through conveying line rather than upon elapsed time periods.
- B. Explosion-Proof Sampling System. There are several major differences in an explosion-proof sampler as compared to a standard sampling system. An explosion proof sampler will typically have the following features.
 - 1. An explosion-proof solenoid on the directional control valve with the rating of:
 - Class 1, Groups C & D, Division 1 & 2
 - Class 2, Groups E, F & G, Division 1 & 2
 - 2. An explosion-proof limit switch with the rating of:
 - Class 1, Groups C & D, Division 1 & 2
 - Class 2, Groups E, F & G, Division 1 & 2

The explosion proof sampler control is available in two enclosure classifications.

- 1. The NEMA 9 control with the rating of:
 - Class 2, Groups E, F & G, Division 1 & 2
 - 2. The NEMA 7 control with the rating of:
 - Class 1, Groups C & D, Division 1 & 2
 - Class 2, Groups E, F & G, Division 1 & 2
- C. Components of special materials, such as 316 stainless steel, monel, inconel or nedox coatings.
 - D. Programmable Controls to sequence the sampler and the sample collection equipment.

2.3 Material Sampled

Most materials from light to heavy density powders, granules, flakes and pellets.

2.4 Sampler Construction

Standard sampler housing construction is of painted carbon steel. This includes the frame, mount plate, sample hopper and guards. The sample probe is of Type 304 Stainless Steel. Other materials and/or finishes appropriate to the operating environment and the material or product being sampled may be used. Refer to the certified drawing(s) for any optional or special components installed on the sampler.

III. GENERAL INSTALLATION REQUIREMENTS

3.1 Receiving Inspection

Carefully inspect the sampling system for damage as soon as it is received. Also, verify that the quantity of parts or packages actually received corresponds to the quantity shown on the packing slip. Report any damage or shortage to the delivering carrier as soon as possible. Intersystems' responsibility for the equipment ended with acceptance by the delivering carrier. Refer to the bill of lading.

3.2 Pre-Installation Preparation

Note, before starting sampling system installation, study this manual, the certified drawing(s) furnished with the system, and other applicable documents (including, but not limited to OSHA Regulations; the National Electrical Code; and all other applicable federal, state, and local codes and regulations).

3.3 Location

The HD-PRT sampler is typically mounted horizontally in the chute at the discharge end of a belt conveyor carrying the product to be sampled, as in Figure 2-1. If this is the arrangement to be used, maintain a minimum of 6" clearance between the end of the sample probe and the face of the head or drive pulley. If the conveyor belt has cleats, maintain a 6" minimum clearance between the end of the sample probe and the tips of the cleats. Reasons for maintaining the minimum clearance includes:

- A. To prevent damage to the sample probe resulting from a drive pulley wobbling on its shaft or from a flap of loose or damaged belt.
- B. To prevent conveyed product or material from jamming in the gap between the pulley and the sample probe.
- C. To insure that complete, representative samples are collected. The sample probe should extend under the drive pulley to ensure that all fines are collected.

The sampler and associated equipment should be located for ease of access and maintenance.

The sampler is to be installed only as shown on the certified drawing(s). If an alternate mounting arrangement is desired, contact Intersystems prior to installation for proper guidance. The sampler is of a general design with modifications specifically for your application. It may be necessary to rework the sampler in order for it to function properly if you alter the application.

3.4 General Mounting Guidelines

The sampler assembly is designed to support ONLY its own weight. As shown on the certified drawing of the sampler, the sampler must be installed with additional hanger rods or braces to rigidly support the sampler. Support should bear on the side support angles located toward the rear on each side of the sampler frame. Each angle has two 7/8" diameter holes for securing the angles to the support(s). Refer to the certified drawing(s) of the sampler for the dimensioned locations of these holes. The hangers or braces should be capable of fully supporting the sampler.

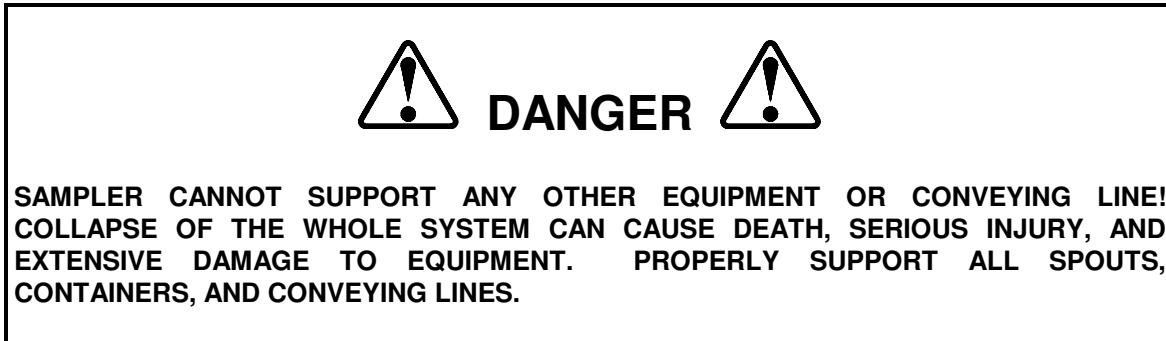

NOTE: IF THE SURFACE AREA TO WHICH THE MOUNTING PLATE IS TO BE ATTACHED IS WARPED OR BENT, STRAIGHTEN AND SMOOTH THE METAL SO THE SAMPLER WILL BE PROPERLY ALIGNED WHEN THE INSTALLATION IS COMPLETE. THE SURFACE TO WHICH THE SAMPLER IS MOUNTED MUST NOT FLEX.

3.4.1 Sampler Without Optional Mounting Accessories

Weld-on plates are typically used when mounting the sampler to a large existing surface, such as on a storage hopper or a long section of chutework.

- A. Locate and mark the desired mounting location on the discharge chute, spout, or conveying line.
- B. Cut and deburr a clearance hole in the chute where the sample probe is to enter the chute. This hole will need to be 8" diameter for the 5.50" dia HD-PRT probe or 11" diameter for the 8.50" dia HD-PRT probe. Refer to the certified drawing(s).
- C. The mounting flange on the end of the sampler drive housing has six 0.88 (7/8") clearance holes for 3/4" mounting screws or studs. Using the sampler mounting face as a pattern, layout or transfer punch the hole locations onto the conveying line.
- D. Drill and tap the holes for the mounting screws, or weld studs to the conveying line for fastening the sampler.
- E. Position the sampler on the conveying line and loosely install the mounting fasteners. Verify that the sample probe will extend and retract without interference. The probe should be centered in the clearance hole. Tighten the mounting fasteners.
- F. Finally, attach the sample discharge hopper to the sampler.
- G. The user or installer must provide hanger rods or braces to rigidly support the sampler. Support should bear on the side support angles located toward the rear on each side of the sampler frame. Each angle has two 7/8" diameter holes for securing the angles to the support(s). Refer to the certified drawing(s) of the sampler for the dimensioned locations of these holes. The hangers or braces should be capable of fully supporting the sampler.

3.4.2 Field-Mounted Sampler Using Weld-On Plate

Weld-on plates are typically used when mounting the sampler to a large existing surface, such as on a storage hopper or a long section of chutework.

- A. Locate and mark the desired mounting location on the conveying line.
- B. Cut and deburr a clearance hole in the chute where the sample probe is to enter the conveying line. This hole will need to be 8" diameter for the 5.50" dia HD-PRT probe or 11" diameter for the 8.50" dia HD-PRT probe. Refer to the certified drawing(s).
- C. Position the sampler mounting plate by aligning the sample probe clearance holes.
- D. Tack weld the sides of the mounting plate to the product line surface and double check alignment.
- E. Weld a continuous bead around all sides of the mounting plate.

NOTE: WHEN WELDING THE MOUNTING PLATE TO THIN GAUGE SHEET OR THIN PLATE, SKIP WELD ALTERNATING SIDES OF THE MOUNTING PLATE TO LIMIT HEAT INPUT TO MINIMIZE WARPING.

- F. Position the sampler on the conveying line and loosely install the mounting fasteners. Verify that the sample probe will extend and retract without interference. The probe should be centered in the clearance hole. Tighten the mounting fasteners.
- G. Finally, attach the sample discharge hopper to the sampler.
- H. The user or installer must provide hanger rods or braces to rigidly support the sampler. Support should bear on the side support angles located toward the rear on each side of the sampler frame. Each angle has two 7/8" diameter holes for securing the angles to the support(s). Refer to the certified drawing(s) of the sampler for the dimensioned locations of these holes. The hangers or braces should be capable of fully supporting the sampler.

3.5 Material Sample Transport Lines

The tubing used to transport material samples must be adequately sized and compatible with the operating environment and the material sampled. Tubing size is usually determined by the size of the flanged discharge chute outlet as shown on the certified drawing(s) furnished with the sampler. All sample lines must be installed either vertically or at a maximum slope to ensure the sampled material flows freely. Use rigid tubing having a smooth interior surface. The sample line is routed to allow material to flow via gravity to a convenient collection point. At that point it may be connected to a collection jar bracket or a Sample Collection System cabinet.

Make all connections airtight and make sure all interior surfaces of joints are smooth and flush. Any ragged or raised tube ends will collect dust and debris as well as retard material flow. Escaping sample material can contaminate surrounding atmosphere and equipment.

3.6 Controller Location

- A. Use vibration isolation pads when mounting the control enclosure or mount the controller in a vibration-free location.
- B. Unless ordered for severe duty, locate controller so it is protected from water and dust.
- C. Unless an explosion-proof rated controller was specifically ordered, DO NOT locate the controller in a hazardous area.
- D. Most applications require that the sampler be in easy view of the controller.

3.7 System Wiring

Refer to the certified electrical drawing(s) for specific wiring requirements. As explained in Paragraph 4.1.10, the terminal strip mounted INSIDE the controller enclosure is the connection point for ALL external circuitry.

The controller was completely assembled and tested with the sampler before it left the factory. The electrical installation must comply with OSHA Regulations; the National Electrical Code; and all other applicable federal, state, and local codes and regulations.

If wiring between the controller and the sampler unit is run through rigid conduit, use a short length of flexible conduit to connect wiring to the sampler. This will isolate the rigid conduit from any vibration originating in the product conveying line and sampler.

3.7.1 Electrical Power Requirements, System

110/120 VAC 50/60 Hz, Single Phase, 10 Amp Service.
Optional - 220/240 VAC 50/60 Hz, Single Phase, 5 Amp Service.

Refer to the certified electrical drawing(s) for specific wiring requirements. InterSystems strongly recommends that electrical service to the sampling system be an isolated line. Voltage fluctuations and line noise can affect the controller's circuit board, thus causing the sampler to malfunction.

3.7.1.1 Controller

110/120 VAC, 50/60 Hz, Single Phase, 4 Amp Max. (includes motor power requirements).
Optional - 220/240 VAC, 50/60 Hz, Single Phase, 2 Amp Max. (includes motor power requirements).

3.7.1.2 Solenoid Valve Coil

110/120 VAC, 50/60 Hz, Single Phase, 5 Watts.
Optional - 220/240 VAC, 50/60 Hz, Single Phase, 5 Watts.

3.8 System Piping

NOTE: USE ONLY CLEANED, PICKLED, DESCALED, AND OILED PIPE FOR AIR SUPPLY LINES. DIRT, SCALE, AND DEBRIS USUALLY FOUND IN STANDARD PIPE QUICKLY CLOGS FILTER/REGULATORS, VALVES, ETC. USE ONLY TEFLON TAPE TO SEAL PIPE JOINTS. CAREFULLY APPLY THE TAPE TO PIPE AND FITTINGS SO NO FRAGMENTS ENTER THE SYSTEM.

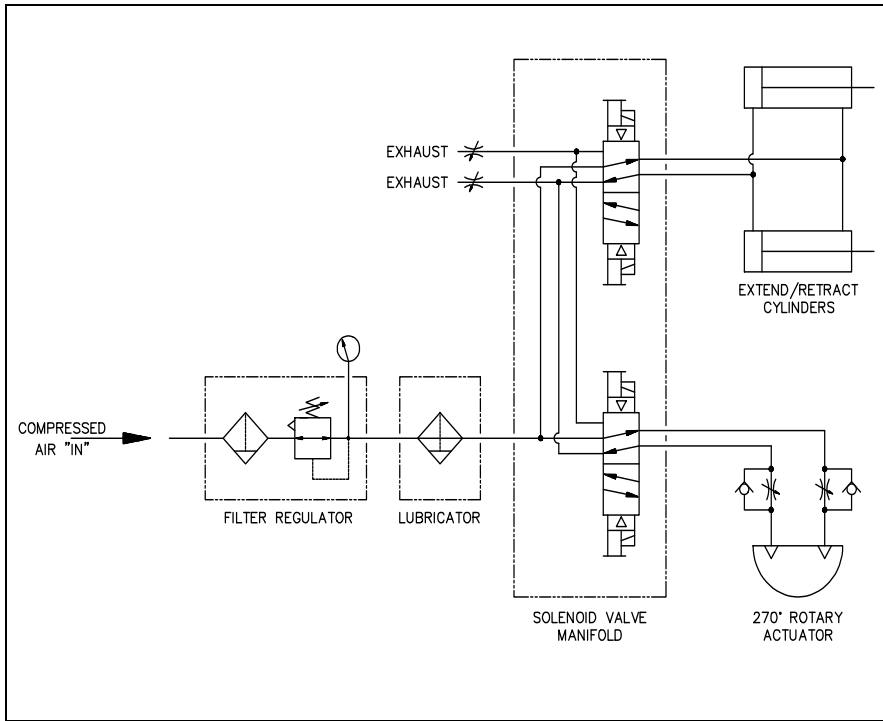

The pneumatic system was pre-plumbed and tested with the sampler before it left the factory. The final installation must comply with OSHA Regulations and all other applicable federal, state, and local codes and regulations.

As shown on the certified drawing(s), the solenoid valves and filter/regulator (F/R) were mounted on the sampler at the factory. The user or installer must pipe the compressed air supply to the F/R. Minimum pipe size for the air supply to the filter/regulator is 1" NPT, reduced to 3/4" NPT at sampler. Larger piping to the sampler, and/or a 30 gallon surge tank located at the sampler, will be required on installations where the compressed air source is further than 200 feet from the sampler to prevent excessive drop in air pressure.

FIGURE 3-1, PNEUMATIC SCHEMATIC

Intersystems recommends installing a shutoff valve upstream of the filter/regulator. A shutoff valve facilitates maintenance as it allows the sampler's pneumatic system to be maintained and repaired without shutting down other equipment supplied from the same air source.

3.8.1 Compressed Air Consumption



A complete sampling cycle requires that the cylinder retract and extend and that the rotary actuator rotates the sample probe twice through a 270° arc during each cycle. To determine the compressed air requirements to operate the sampler, multiply the consumption per cycle (refer to chart) by the number of cycles per minute. The number calculated is the SCFM (Standard Cubic Feet per Minute) of air required. A typical cycle takes between 10-20 seconds, depending on the sampler size and control settings.

MODEL/SIZE	AIR CONSUMPTION PER SAMPLE CYCLE @ 80 PSI	
	5.50" dia Probe	8.50" dia Probe
HD-PRT - 12	6.2 SCF	8.8 SCF
HD-PRT - 18	8.1 SCF	11.5 SCF
HD-PRT - 24	10.0 SCF	14.3 SCF
HD-PRT - 30	11.9 SCF	17.0 SCF
HD-PRT - 36	13.8 SCF	19.7 SCF
HD-PRT - 42	15.7 SCF	22.4 SCF
HD-PRT - 48	17.6 SCF	25.2 SCF
HD-PRT - 54	19.5 SCF	27.9 SCF

The pneumatic system on the sampler, consisting of the filter/regulator, directional control valve and air cylinder was pre-plumbed and tested at the factory. The regulator is factory set at 80 PSI.

The regulator cannot increase downstream outlet pressure above the upstream inlet pressure. If the pressure from the regulator is not sufficient to operate the cylinder, some means must be found to increase the inlet pressure to the regulator. Recommended air supply pressure is 80-100 PSI.

IV. OPERATIONS AND ADJUSTMENTS

**DANGER**

FAILURE TO OBSERVE ALL SAFETY RULES, WRITTEN AND IMPLIED, AND THOSE SUGGESTED BY COMMON SENSE, CAN RESULT IN DEATH, SERIOUS INJURY, AND /OR EQUIPMENT DAMAGE. LOCKOUT POWER BEFORE PERFORMING ANY MAINTENANCE.

4.1 Control Components And Their Functions

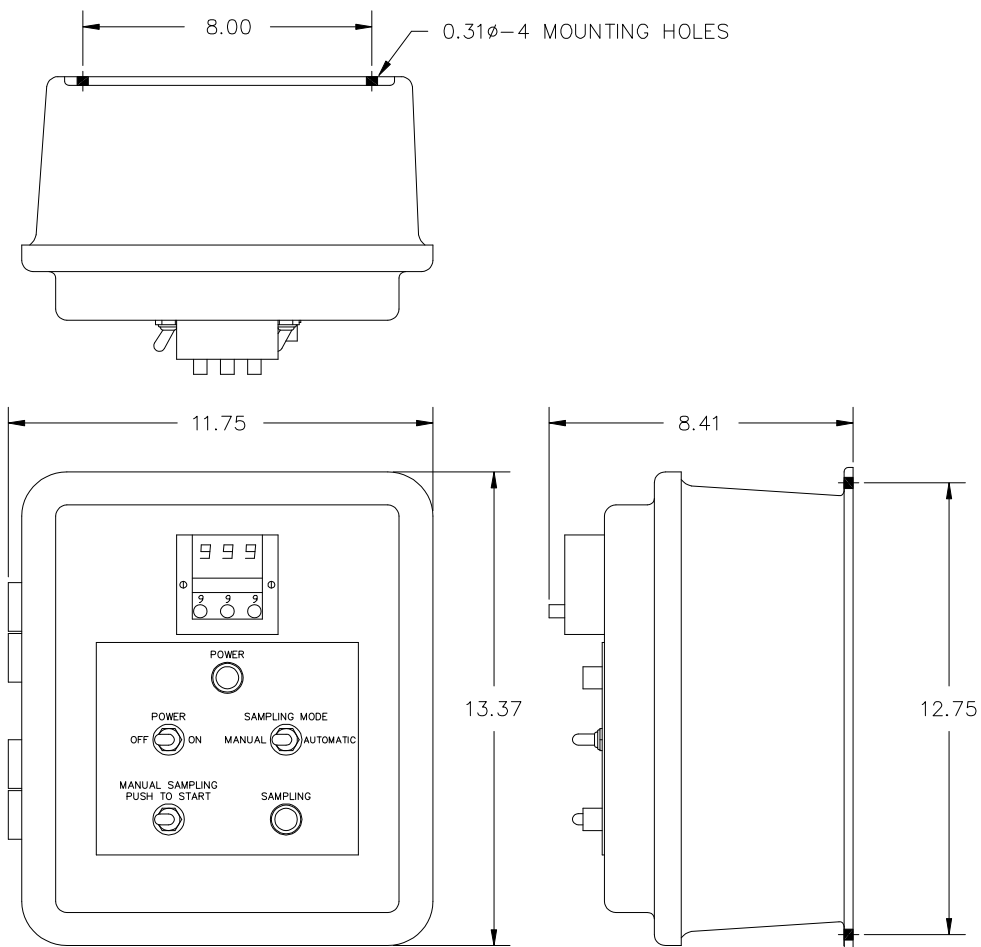
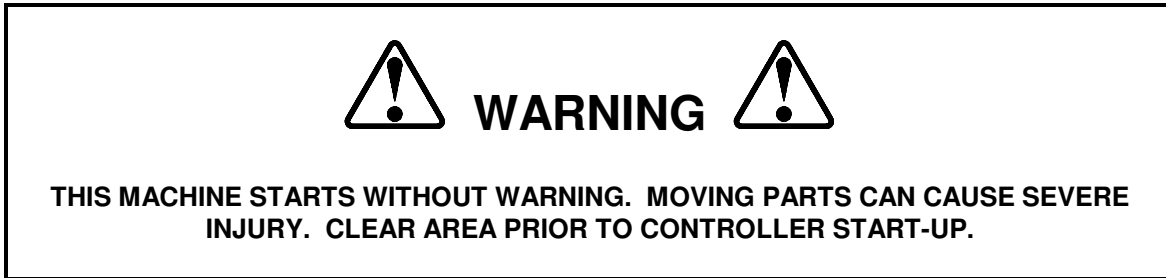

FIGURE 4-1, STANDARD NEMA 4 CONTROL PANEL DETAIL

Refer to the certified electrical drawing(s) for dimensions on control panels with optional features.

4.1.1 POWER OFF/ON Switch S-2

This toggle switch controls all electrical power to the controller and the sampler unit.



4.1.2 SAMPLING MODE Switch S-3 (Automatic/Manual)

This switch permits the operator to select whether samples will be collected automatically at precisely timed or counted intervals as determined by the Digital Display Timer T-1 or Counter C-1, OR manually whenever the operator momentarily actuates the MANUAL SAMPLING toggle switch (S-4).

4.1.3 MANUAL SAMPLING Switch S-4

This switch functions ONLY when the AUTO/MANUAL switch has been set to the Manual Mode position. Switch S-4 is a spring-return switch that is maintained in the OFF or Normally Open position. Correct operating procedure is to momentarily actuate S-4 to the Start position. When the SAMPLING light is illuminated, release the switch. The sampler will complete its cycle without further operator intervention.

4.1.4 POWER Pilot Light

This light is illuminated as long as power is available to the controller and the POWER switch (S-2) is set to ON.

4.1.5 SAMPLING Pilot Light

This light will illuminate when a sampling cycle has been initiated and will stay lit until the sampling cycle has completed.

4.1.6 Digital Display Timer T-1 (Standard)

As arranged for use in this system, the timer operates in the DOWN & STOP mode. When the AUTO mode is selected, the illuminated display resets to the value dialed in to the Three Digit Preset. Immediately, the timer begins timing down. When the illuminated display reads all zeroes (000), the timer has "timed out" and initiates a sampling cycle. The sample probe extends, rotates to collect a sample, retracts, and finally dumps the collected sample. The timer display resets to the preset value and another timing interval is initiated. If the controller is shut off or the mode switched from AUTO to MANUAL, the timing cycle is terminated. When power is restored or the AUTO mode is again selected, the display is reset to the preset value and another cycle begins. NOTE: A new timing cycle can be initiated ONLY after the sampling cycle has completed.

- A. External Settings

1. THE DISPLAY:

The high intensity blue fluorescent display consists of three digits and decimal point (if decimal is set in tenths or hundredths position). Also, there is a blinking Timing Bar and a special Time-Out symbol. The Timing Bar appears to the right of the digits and blinks once every second during timing. The Timing Bar shows quickly that the timer is actively timing especially when the digits do not change rapidly as in the "hours" ranges. When the delay relay is energized at time-out, a triangular Time-Out symbol appears to the left of the digits. The Timing Bar blinks noticeably faster at time-out.

2. SETTING SWITCHES:

The three digits are set with the rotary switch knobs located beneath each digit. These knobs can be rotated in either direction (CW or CCW), and they are "pull" removable if digit set security is desired. Changing one or more digits, during timing, will instantly be reflected by an equivalent change in the timer's display. Setting all three digits to zero will cause instant time-out of the timer.

B. Internal Settings

THE 365 DIGITAL DISPLAY TIMER MUST BE REMOVED FROM ITS HOUSING TO ALTER ANY OF THE FOLLOWING SETTINGS.

1. TIME RANGE:

Decimal Point Location can be changed with the white plastic lever mounted behind the front face of the timer. This lever moves into three positions. With finger force you can change its position and at the same time observe the front of the timer. NOTE - this procedure sets the decimal point electronically as well as visually.

Time Units (Sec/Min/Hr) are set by moving a small width metal arm in a slotted arc on the side plate nearest to the units (Sec/Min/Hr) window. By depressing this arm slightly with a pencil or pen point, it can be moved to a new position. The time units physically change in the timer's face and the timer is electronically switched to the new units as well.

2. LINE FREQUENCY:

To set the proper line frequency, connect the jumper wire to either the 50 HZ or 60 HZ pin. These pins are clearly marked on the side of the timer.

NOTE: THE TIMER CHASSIS AND THE HOUSING ARE POLARIZED SO THAT THE CHASSIS CANNOT BE INSERTED INTO ITS HOUSING UPSIDE-DOWN. IF THE TIMER IS FORCED INTO THE HOUSING UPSIDE-DOWN DAMAGE WILL RESULT.

4.1.7 Digital Display Counter C-1 (Optional)

As arranged for use in this system, the counter operates in the DOWN & STOP mode. When the AUTO mode is selected, the illuminated display resets to the value dialed in to the Three Digit Preset. Immediately, the counter begins counting down. When the illuminated display reads all zeroes (000), the counter has "counted out" and initiates a sampling cycle. The sample probe extends, rotates to collect a sample, retracts, and finally dumps the collected sample. The counter display resets to the preset value and another counting interval is initiated. If the controller is shut off or the mode switched from AUTO to MANUAL, the counting cycle is terminated. When power is restored or the AUTO mode is again selected, the display is reset to the preset value and another cycle begins. NOTE: A new counting cycle can be initiated ONLY after the sampling cycle has completed.

A. External Settings

1. THE DISPLAY:

The high intensity blue fluorescent display consists of three digits and a Counting Bar with a special Count-Out symbol. The Counting Bar appears to the right of the digits and blinks once every count, regardless of range. When the delay relay is energized at count-out, a triangular Count-Out symbol appears to the left of the digits.

2. SETTING SWITCHES:

The three digits are set with the rotary switch knobs located beneath each digit. These knobs can be rotated in either direction (CW or CCW), and they are "pull" removable, if digit set security is desired. Changing one or more digits, during counting, will instantly be reflected by an equivalent change in the counter's display. Setting all three digits to zero will cause instant count-out of the counter.

B. Internal Settings

THE 366 DIGITAL DISPLAY COUNTER MUST BE REMOVED FROM ITS HOUSING TO ALTER THE COUNT RANGE:

The 366 has three ranges.

1x	=	Counts single pulses to 999
10x	=	Counts every tenth pulse to 9,990
100x	=	Counts every hundredth pulse to 99,900

Each range is selectable using finger force on the white plastic lever behind the front face of the counter. In two of the three possible lever positions, an indicator will appear in a range window located on the front face of the counter. When nothing appears in this window the count is in the x 1 range.

NOTE: THE COUNTER CHASSIS AND THE HOUSING ARE POLARIZED SO THAT THE CHASSIS CANNOT BE INSERTED INTO ITS HOUSING UPSIDE-DOWN. IF THE COUNTER IS FORCED INTO THE HOUSING UPSIDE-DOWN DAMAGE WILL RESULT.

4.1.8 Probe Jam Timer T-2

This internal timer starts timing after the sample probe has started to retract, when the sample probe extended limit switch (LS-1) is de-actuated. This timer monitors the total time it takes for the sample probe to fully retract and rotate to the six o'clock position. If the sample probe fails to perform these functions in the allotted time (Timer T-2 time setting) the sample probe will extend, reset timer T-2 and try to retract and rotate to 6 o'clock again. This action will be repeated until it is successful. An approximate setting of 6 to 10 seconds is required to allow the sampler to cycle normally.

4.1.9 Main Fuse

This fuse, located in a fuse block within the controller enclosure, protects the controller and sampler components against overloads and short circuits.

For 110/120 VAC, 1PH operation use ONLY a Buss Type FNM, 4 Amp, 250 Volt Slo-Blo fuse or equal.

For 220/240 VAC, 1PH operation use ONLY a Buss Type FNM, 2 Amp, 250 Volt Slo-Blo fuse or equal.

4.1.10 Terminal Strip

This 24-position barrier terminal strip is fastened to the sub-plate within the controller enclosure. It serves as the controller's interface with and connection point for all external circuits and for the components mounted on the enclosure's front panel. Refer to the Certified Electrical Drawing(s).

4.2 Sampler Mounted Electrical Components

4.2.1 Sample Probe EXTENDED Limit Switch, LS-1

This switch is actuated when the sample probe is fully extended into the product stream. Closing of the N.O. contacts energizes the "A" coil of the rotation control valve, V-2. The rotary actuator causes the sample probe to rotate clockwise (when viewed from the rotary actuator end of the sampler) from the six o'clock to the three o'clock position to collect a sample. The switch is restored when the cylinders retract the sample probe from the product stream.

4.2.2 Sample Probe RETRACTED Limit Switch, LS-2 (actuated at rest)

This switch is actuated when the sample probe is fully retracted from the product stream. Closing of the N.O. contacts energizes the "B" coil of the rotation control valve, V-2, which rotates the sample probe counter-clockwise (when viewed from the rotary actuator end of the sampler) from the three o'clock position to the six o'clock position to dump the sample into the discharge chute. The switch is actuated at rest and restores when the cylinders extend at the beginning of a cycle.

4.2.3 Sample Probe @ SIX O'CLOCK Limit Switch, LS-3 (actuated at rest)

This switch is actuated when the rotary actuator has rotated fully counter-clockwise to the six o'clock position. Closing of the N.O. contacts signals a sample cycle is complete and allows the digital display timer to run (in the automatic mode). An automatic or manual sample cycle may be initiated if, and only if, this switch is actuated. The switch is actuated at rest and restores when the rotary actuator begins to rotate to sample.

4.2.4 Sample Probe @ THREE O'CLOCK Limit Switch, LS-4

This switch is actuated when the rotary actuator has rotated fully clockwise to the three o'clock position. Closing of the N.O. contacts energizes the "B" coil of the EXTEND/RETRACT control valve, V-1. The switch restores later in the cycle when the sample probe rotates to dump the sample.

4.3 Pneumatic Components

4.3.1 Solenoid Valves V-1 And V-2

These valves are 4-way, 2-position, double-solenoid operated, maintained-position directional control valves.

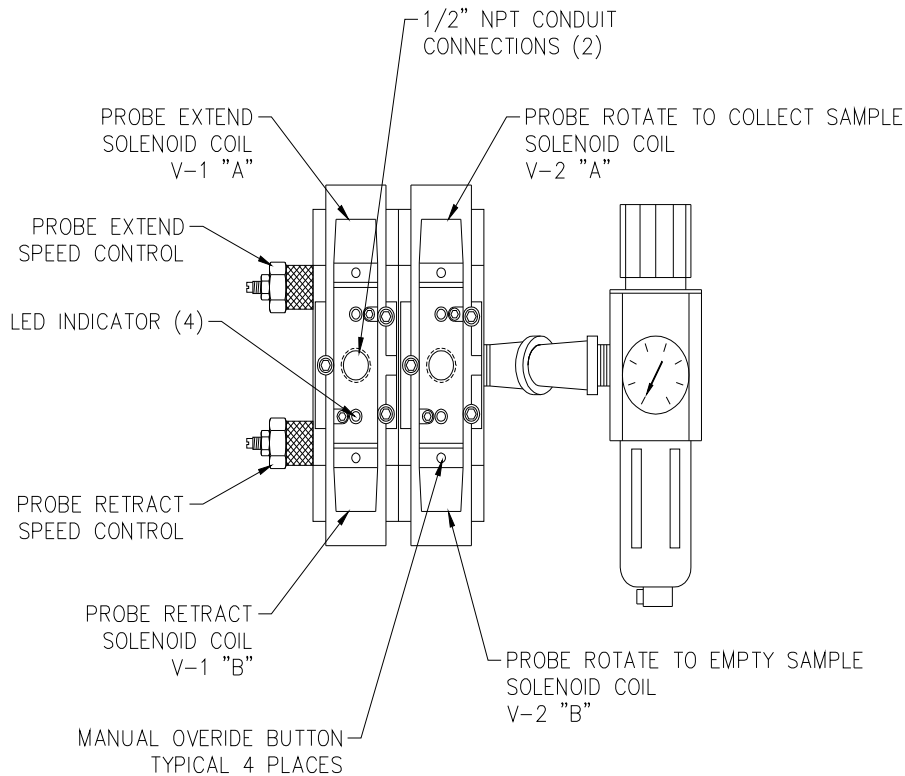

FIGURE 4-2, SOLENOID VALVE

4.3.1.1 Sample Probe EXTEND/RETRACT Valve V-1

This solenoid-operated directional control valve alternately pressurizes the piston end and rod end of two double-acting cylinders to extend and retract the sample probe. When the valve's "A" solenoid is momentarily energized, the valve spool shifts, pressurizing the rod ends of the cylinders. The cylinders retract, extending the sample probe into the product stream. When the "B" solenoid is momentarily energized, the valve spool shifts, pressurizing the piston ends of the cylinders. The cylinders extend, retracting the sample probe from the product stream.

4.3.1.2 Sample Probe ROTATE Valve V-2

This solenoid-operated directional control valve alternately pressurizes opposing ports of the rotary actuator to rotate the sample clockwise (CW) to collect samples and counter-clockwise (CCW) to dump samples (when viewed from the rotary actuator end of the sampler). When the valve's "A" solenoid is momentarily energized, the valve spool shifts, pressurizing the CW port of the actuator. The sample probe rotates, collecting a sample of the material from the product stream. When the "B" solenoid is momentarily energized, the valve spool shifts, pressurizing the CCW port of the actuator. The sample probe rotates, dumping the collected sample.

4.3.2 Rotation Speed Controls

Needle valves are supplied in the airlines leading from the ports of the rotary actuator. Each needle valve can be adjusted to restrict the flow of air FROM the actuator port to which it is connected and control the rotational speed at which the actuator rotates the sample probe in one direction. The arrow on the valve body indicating the direction of controlled air flow should point AWAY from the valve port.

4.3.3 Probe Extend/Retract Speed Control Valve Adjustment

A speed control valve is threaded into each exhaust port of Valve V-1. See Figure 4-2. Each speed control valve controls the rate at which air exhausts from one end of the cylinder and as a result, controls cylinder operating speed in only one direction. The speed controls were factory set but may need minor adjustment due to differences in air supplies. Use the following guidelines when adjusting the speed controls.

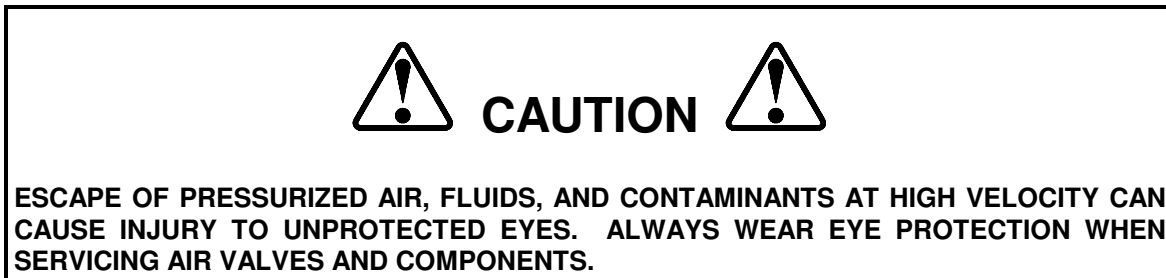

- A. Turn the nut locking the one speed control valve's metering screw clockwise to loosen it. (NOTE: left hand threads). Do not allow metering screw to turn.
- B. Change control switch to manual mode and initiate a manual sample. While operating the sampler, turn the metering screw to vary the speed of cylinder operation. Turn the screw clockwise to decrease speed, or turn the screw counterclockwise to increase speed.
- C. When the desired cylinder operating speed in one direction has been achieved, tighten the nut to lock the adjustment and repeat procedure to adjust the other speed control valve.

4.3.4 Air Filter/Pressure Regulator

The air filter/regulator assembly provides a clean and regulated air supply to the samplers pneumatic components. A pressure gauge gives the operator an accurate reading of the downstream air pressure. The regulator is equipped with an adjustment knob for controlling the outlet pressure and a manual type drain for draining the filter bowl.

Prior to introduction of air supply, turn the adjustment knob counter-clockwise until all load is removed from the regulating spring. Turn on system air pressure. Turn adjustment knob clockwise until desired outlet pressure is reached.

To avoid minor re-adjustments after making a change in the pressure setting, always approach the desired setting from a lower pressure. When reducing from a higher setting to a lower setting, first reduce to a pressure setting lower than desired and then adjust upward.

To "lock-in" the pressure setting on the regulator, push the locking on the adjustment knob down until it snaps into place. To release pull the locking upward. The pressure setting can be made tamper resistant by installing a seal wire in the groove above the locking.

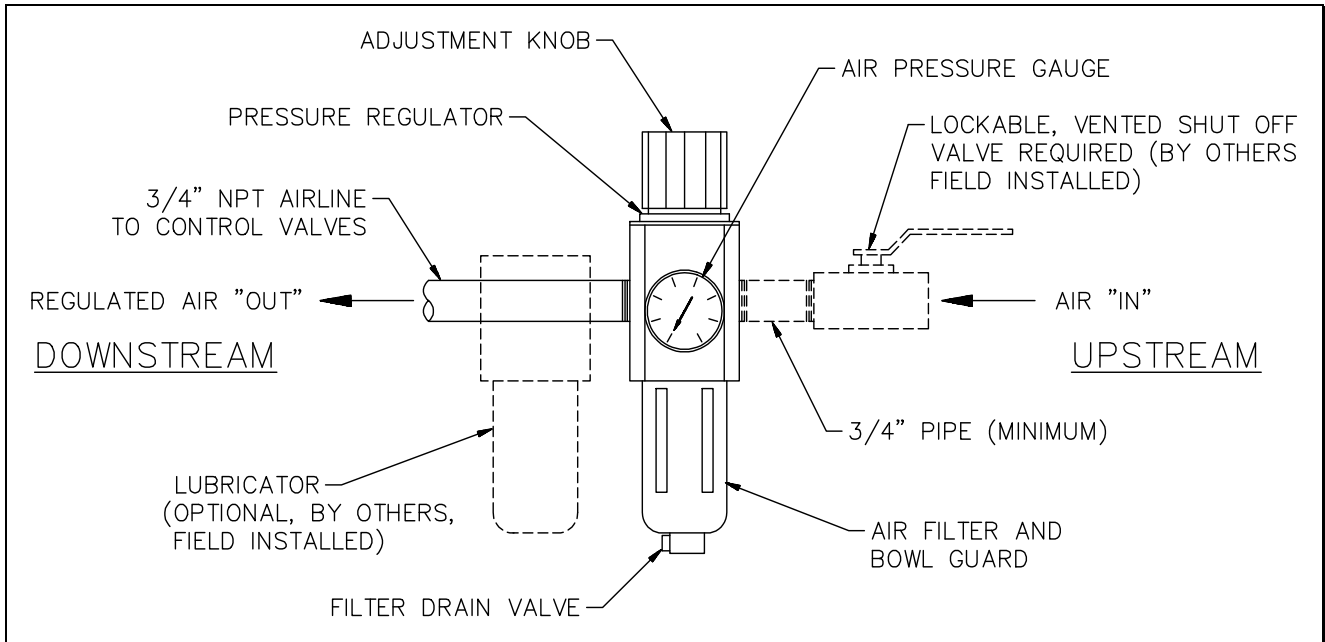

FIGURE 4-3, FILTER/REGULATOR

4.3.5 Pneumatic Cylinders

These double-acting, non-cushioned rod cylinders extend and retract the sample probe. Stroke length varies with the sample probe stroke. Cylinder rods are attached to the sample probe assembly using an alignment coupler. Solenoid valve V-1 controls extension and retraction of the cylinders.

4.3.6 Rotary Actuator

The actuator is essentially two double acting air cylinders that drive a rack and pinion unit, thus converting linear motion into rotary motion. The actuator is coupled directly to the sample probe, alternately rotating the sample probe clockwise to collect samples and counter-clockwise to dump samples. Solenoid valve V-2 controls rotary actuator motions.

4.4 Shock Absorbers

These devices prevent impact damage to the sampler in the occasional instance when sampled material prevents the smooth, immediate, and complete retraction of the sample probe. This can happen when a fragment of the sample material protrudes from the slot in the sample probe and the probe is prevented from retracting completely. Once the air cylinders build pressure the fragment is sheared. The shock absorbers prevent the sudden freeing of the sample probe would allow the cylinders and sample probe to violently impact against the frame.

V. MAINTENANCE AND REPAIR



FAILURE TO OBSERVE ALL SAFETY RULES, WRITTEN AND IMPLIED, AND THOSE SUGGESTED BY COMMON SENSE, CAN RESULT IN DEATH, SERIOUS INJURY, AND /OR EQUIPMENT DAMAGE. LOCKOUT POWER BEFORE PERFORMING ANY MAINTENANCE.

5.1 General Maintenance

A good maintenance program involves thorough general housekeeping, adequate periodic re-lubrication, and replacement of worn or damaged components.

5.2 Periodic Inspection

At regularly scheduled intervals, while observing all safety precautions, observe the sampler as it operates. Inspect for:

- A. Loose or missing hardware
- B. Functioning and properly adjusted shock absorbers.
- C. Structural damage
- D. Rust or corrosion
- E. Damaged wiring, including exposed conductors and connections
- F. Damaged airlines or pneumatic components
- G. Keep the areas around the limit switches clear of accumulations of dirt and debris which might prevent the switches from functioning as intended.
- H. Make sure that all guards are in place and that all warning labels are in place and legible. Section I, GENERAL SAFETY INFORMATION, explains the purpose and intended location of the warning signs. Warning signs are an important part of any safety program; replace any missing signs IMMEDIATELY!

5.3 Lubrication

5.3.1 Guide Bushings and Drive Bearings

All shafts and bearings have been coated with a liberal amount of multi-purpose grease. Bearings and shafts should be thoroughly cleaned and re-greased once a year. It is essential that all covers remain fastened in place to prevent the entrance of dust and dirt, which would contaminate the grease.

5.3.2 Airline Lubricator

An airline lubricator is not required. The cylinders and the rotary actuator are of a non-lube design requiring NO lubrication. If the use of a lubricator is desired, it must be field mounted between the F/R and the directional control valve. If a lubricator has been added to the system, the user must determine the appropriate lubricant and the proper intervals for refilling the reservoir. Refer to the manufacturer's technical literature. Note that by introducing oil into the airline, it will be discharged into the surrounding environment near the air exhausts of the directional control valves on the sampler.

5.4 Draining and Servicing the Filter

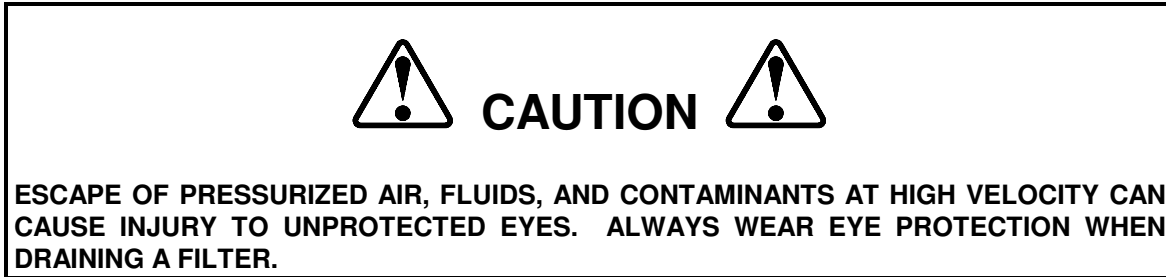

Drain the accumulated fluid whenever the fluid level in the reservoir (quiet-zone) rises to the lower baffle. Filters have either a screw-type drain or a push-type drain. If the filter requires frequent draining, consider installing an automatic drain or an air drying system. Periodically, the bowl may need to be removed to clean out accumulated moisture and contaminants.

- A. Shut off and lock out the air supply.
- B. Operate a valve or loosen an airline connection to relieve all pressure downstream from the filter/regulator.
- C. Remove and clean the bowl; various types of clamp rings or threaded collars are used to retain bowls.

NOTE: THE BOWLS OF FILTER/REGULATORS CAN NOT BE REMOVED WHILE PRESSURIZED! INTERNAL PRESSURE PREVENTS THE CLAMP RING OR THREADED COLLAR FROM TURNING.

- D. Clean or replace the filter element.
- E. If the bowl seal is damaged or brittle replace it. In any event lightly coat the seal with petroleum-based grease to help hold it in position.
- F. Reinstall the bowl. Turn on pressure and make sure the bowl is seated and sealed.



5.5 Rotation Reversal

Depending on the installation it may be desirable to reverse the rotation of the sampler probe to prevent material from flowing into the sample slot when the probe is in the 3 o'clock position. This is typically encountered in an installation where the sampler is probing from a sideways moving pile of material as in a drag conveyor or truck pit. The sampler is re-configured as follows.

- A. Shut off and lockout all power (electrical and pneumatic).
- B. Shut down the conveying line or conveyor when empty and lockout.
- C. Remove the top cover(s) of the sampler and the access cover on the sample hopper.
- D. Remove the 1/4-20UNC hex head bolts attaching the shear nose, bearing & locator.
- E. Rotate the serrated shear nose 180 degrees.
- F. Re-install the 1/4-20UNC hex head bolts and tighten.
- G. Remove the four 1/2-13UNC hex head nuts and washers attaching the drive bearing to the probe, and slide the drive bearings off the probe.
- H. Without moving the square drive tube rotate the probe 90 degrees clockwise (as viewed from the actuator end).
- I. Re-install the drive bearing, washers and nuts and tighten.
- J. Re-install the top covers and the sample hopper access cover.
- K. Reverse the electrical wiring from the control to the two rotation solenoids.
- L. Reverse the electrical wiring from the control to the two rotation limit switches.
- M. Make notations in this manual and on the electrical drawings that the limit switches and the solenoids are reversed and re-designate.
- N. Restore power to the sampler and operate it through several collection cycles. It may be necessary to re-adjust the rotation speed control valves. Refer to Section 4.3.2.1.

VI. TROUBLESHOOTING

6.1 General HD-PRT Sampler Troubleshooting

DANGER

CARELESS OR ACCIDENTAL RESTORATION OF POWER CAN RESULT IN DEATH OR SERIOUS INJURY. MAKE CERTAIN AREA IS CLEAR BEFORE REMOVING LOCKOUTS.

SYMPTOM	POSSIBLE CAUSE	CORRECTIVE ACTION
Sampler does not cycle in either auto or manual modes (Power light Off).	Power switch OFF.	Turn power switch ON.
	Circuit breaker is open.	Reset breaker.
	Main fuse is blown.	Replace. Refer to Section 4.1.9.
	Faulty supply wiring.	Correct. Refer to certified electrical schematic.
	Defective power switch.	Replace switch.
Sampler does not cycle in either auto or manual modes (Power light On).	Faulty system wiring.	Correct. Refer to certified electrical schematic.
	Limit switch malfunction.	Inspect. Refer to Sections 4.2.1 to 4.2.4.
	No or low air pressure.	Turn air supply On and set regulator to 80-100 PSI.
	Defective control valve.	Refer to Section 6.2.
Sampler timer T-1 digital display does not illuminate but sampler works in manual mode.	Limit switch LS-3 not actuated.	Inspect.
	Defective auto/manual switch S-2.	Replace switch if line voltage is absent across #1 & #2 on timer T-1.
	Defective timer T-1.	Replace timer if line voltage is present across #1 & #2 on timer T-1.
Sample size too small or large.	Rotational speed of the sample probe too fast or too slow.	Adjust needle valve V-3. Refer to Section 4.3.2. See location as noted on Fig 6-2.

General HD-PRT Sampler Troubleshooting (continued)

SYMPTOM	POSSIBLE CAUSE	CORRECTIVE ACTION
Sampler sluggish (Operates too slowly).	Inadequate air supply.	Increase line size or add surge tank.
	Regulator set too low.	Reset. Refer to Section 4.3.4.
	Filter clogged.	Clean as outlined in Section 5.4.
	Airline from filter regulator blocked or damaged.	Inspect and correct.
	Cylinder seal leakage.	Refer to Section 6.3.1.
Sampler probe continuously extends and retracts.	Timer T-2 setting too low.	Increase time setting. Refer to Section 4.1.8.
	Timer T-2 defective.	Replace.
	Limit switch LS-2 and/or LS-3 not properly set.	Inspect & adjust If limit switch arm bent or loose.
	Limit switch LS-2 and/or LS-3 defective.	Replace if contacts not opening and closing by manually tripping.
Sampler stops with probe extended.	Limit switch LS-1 and/or LS-4 not properly set.	Inspect & adjust If limit switch arm bent or loose.
	Limit switch LS-1 and/or LS-4 defective.	Replace if contacts not opening and closing by manually tripping.
	Sample probe jammed.	Inspect and correct.

6.2 Directional Solenoid Valve Troubleshooting

SYMPTOM	POSSIBLE CAUSE	CORRECTIVE ACTION
Valve does not shift but 120 vac signal is present at the terminal strip inside the control.	No or low air pressure.	Turn on air supply and set regulator to 80-100 PSI.
	Faulty field wiring.	Check for full line voltage at the solenoid.
	Solenoid coil burnt out.	Replace coil if no continuity through coil.
	Valve clogged or stuck.	Remove & clean. Or replace.
Valve leaks air continuously out an exhaust port.	Defective valve seals.	Refer to Section 6.3.2.
	Defective cylinder seals.	Refer to Section 6.3.2.

There must be at least 60 PSI pressure at the valve. The valve pilot operators are air assisted. If there is insufficient pressure the valve will not shift or may not shift completely.

Observe the pressure gauge. Assume the gauge indicates sufficient pressure when the sampler is idle, 85 PSI for example. If the pressure drops significantly to perhaps 55 PSI when the valve shifts, a blocked or damaged air line should be suspected.

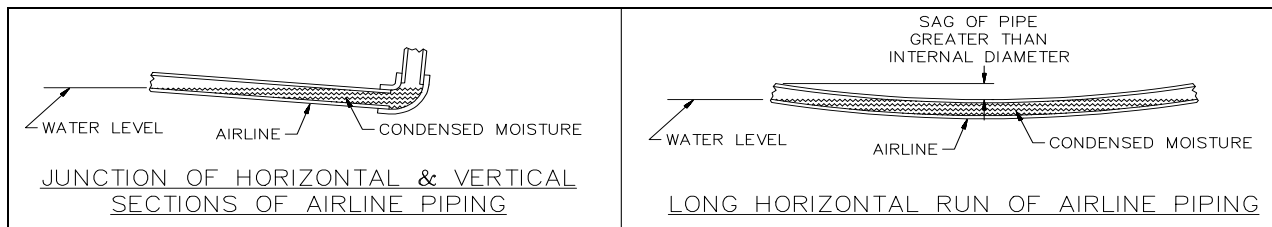

FIGURE 6-1, CONDENSED MOISTURE BLOCKING AIRLINE

One often overlooked cause of insufficient air flow is moisture condensing and collecting in a low spot in the supply line. Figure 6-1 illustrates an exaggerated example of such a problem. It can be seen that if the pipe sags only slightly over a long distance and water collects in the low spot over an extended period of time, the airline could be partially or completely blocked. A similar condition often occurs where there is a junction of horizontal and vertical sections of an air line.

This problem is particularly prevalent when there is high ambient humidity and the equipment operates infrequently and intermittently, as in the case of a sampler.

NOTE: ALL HORIZONTAL RUNS OF AN AIRLINE SHOULD HAVE A MOISTURE TRAP AND THE TRAPS SHOULD BE DRAINED FREQUENTLY; AT LEAST ONCE A DAY; ESPECIALLY, WHEN HUMIDITY LEVELS ARE HIGH.

6.3 Air Components Troubleshooting

6.3.1 Cylinder Leaking

A. External Leakage

1. Rod seal leakage can generally be traced to worn or damaged seals. Examine the piston rod for wear or damage. Replace the rod and seals if rod's surface is rough or worn out-of-round.
2. Soft or gummy seals are evidence of incompatibility with some substance in the air supply. Evaluate the area where the air intake is located. If an airline lubricator is included in the system, check to see if the lubricant being used is compatible with the seal material.

B. Internal Leakage

1. The lipseal piston seals are virtually leak free unless they are worn or damaged. Replace defective seals.
2. Contaminants in the air supply can lead to scored cylinder walls, resulting in rapid seal wear. If such is the case, check to see if the filter is being drained frequently. A different type of filter may be required; one that can remove finer particles or one that can filter out different kinds of contaminants.
3. Possible piston cylinder leakage, apparently indicated by piston drift is not always traceable to the piston. A leak through a closed valve port can also cause piston drift.

To determine if a piston is leaking, use a manual override to pressurize one end of the cylinder in question. When the cylinder has completed its stroke but is still pressurized, carefully remove the airline from the other cylinder port that presumably is not pressurized. If air can be detected leaking from the airline connected to the supposedly unpressurized port, then the problem lies elsewhere in the pneumatic system.

6.3.2 Valve vs. Cylinder Leak Test

When there is continuous leakage out of a valve exhaust port, proceed as follows to determine if the leak is caused by defective valve seals or by defective cylinder seals.

E. A. Cylinder retracted as shown in Figure 6-2A

1. If there is continuous leakage out of Port "5", the valve seals are defective and must be replaced.
2. If there is continuous leakage out of Port "3", the problem can be with the valve seals or the cylinder seals. To determine which proceed as follows:
 - a. Disconnect the line between Valve Cylinder Port "2" and the cylinder per Figure 6-2B.
 - b. If leakage continues out of Port "3" and/or Cylinder Port "2", the valve seals are defective and must be replaced.
 - c. If there is a leakage out of the line from the cylinder, the cylinder seals are defective and must be replaced.

F. B. Cylinder extended as shown in Figure 6-2C.

1. If there is continuous leakage out of Port "3", the valve seals are defective and must be replaced.
2. If there is continuous leakage out of Port "5", the problem can be either the valve seals or the cylinder seals. To determine which proceed as follows:
 - a. Disconnect the line between Valve Cylinder Port "4", and the cylinder per Figure 6-2D
 - b. If leakage continues out of Port "5" and/or Cylinder Port "4", the valve seals are defective and must be replaced.
 - c. If there is a leakage out of the line from the cylinder, the cylinder seals are defective and must be replaced.

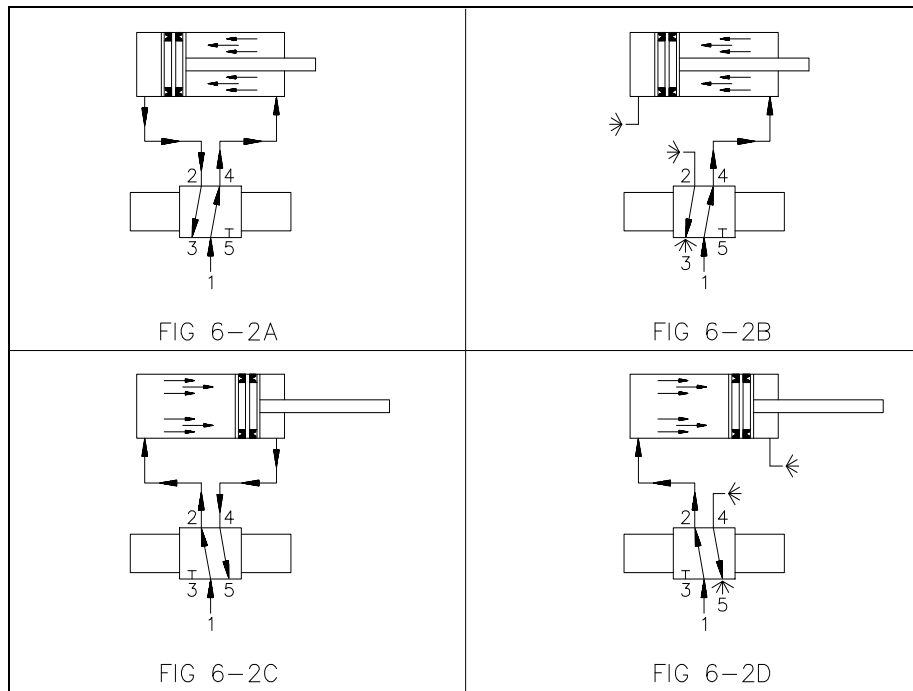

FIGURE 6-2, VALVE VS. CYLINDER LEAK TEST DIAGRAM

VII. REPLACEMENT PARTS

7.1 Scope

The certified drawings list the non-standard components that have been incorporated into the equipment. Intersystems normally stocks non-fabricated parts and non-custom OEM parts. Replacement parts for any other components, including fabricated parts and custom OEM components can be supplied upon request.

7.2 Ordering Parts

Direct parts orders or requests for technical assistance to your sales representative or to:

**Intersystems
9575 N 109th Ave
Omaha, NE 68142
Phone 402.330.1500
Fax 402.330.3350**

Please have available the MODEL NUMBER, SERIAL NUMBER and CUSTOMER ORDER NUMBER of the equipment in question as well as the location where the sampler is INSTALLED.

7.3 Replacement Parts

The Intersystems sampler is a quality built piece of machinery. As with any machine, parts do wear out and fail. It is Intersystems' recommendation that a small supply of spare parts be kept on hand to cover any minor breakdowns. A separate priced Spare Parts List will be sent identifying the suggested spare parts. It is also necessary to check the certified drawings, which will list any special or custom components utilized on this equipment.

7.4 Repair Kits

The Following chart lists repair kits and parts that are available from Intersystems. These kits are offered as a more economical solution by rebuilding the defective part rather than replacing it. However in some cases the part may be beyond repair and replacement will be necessary.

Product Code	Description
522319	Valve repair kit (Automatic Valve)
516551	Standard 110/120 VAC, 50/60 HZ valve coil (Automatic Valve)
529440	Optional 220/240 VAC, 50/60 HZ valve coil (Automatic Valve)
527133	Rod seal kit for 1" rod air cylinder (Parker 2MA series)
527134	Rod seal kit for 1-3/8" rod air cylinder (Parker 2MA series)
525512	Piston seal kit for 5" bore air cylinder (Parker 2MA series)
527855	Piston seal kit for 6" bore air cylinder (Parker 2MA series)
522320	Rotary actuator seal repair kit (Parker PTR322 series)
525425	Rotary actuator seal repair kit (Parker HP4.5 series)
513963	Gauge for filter regulator
524711	Filter element kit for filter regulator (SMC NAW4000 series)
35527	Limit Switch Contact Block 1 N.O. 1 N.C.

This page intentionally left blank

7.4.1 Sampler Parts Listing HD-PRT w/ 5.50" dia Probe (see Figures 7-1 & 7-2)

ITEM NO.	PART NO	DESCRIPTION	QTY
1	519457	3/4 NPT FILTER REGULATOR	1
2	512825	BRASS PIPE CLOSE NIPPLE 3/4 NPT	1
3	35681	BLACK 45° STREET ELBOW 3/4 NPT	2
4	513757	4-WAY NPT SOLENOID VALVE 110/120 VAC 50/60 Hz	2
5	34517	BLACK PIPE PLUG 3/4	7
6	36433	SPEED CONTROL 3/4 NPT	2
7	36441	BLACK PIPE NIPPLE 3/4 X 3	1
8	512437	BLACK PIPE NIPPLE 3/4 X 2	1
9	36442	BLACK PIPE TEE 3/4 NPT	2
10	513288	1/2 PUSH-LOC TO 3/4 MPT STR ADAPTOR	4
11	24558	1/2 PUSH-LOC TO 1/2 MPT STR ADAPTOR	4
12	513290	BRASS 90° STREET ELBOW 1/2 NPT	4
13	36445	PIPE BUSHING 3/4 X 3/8	2
14	24553	3/8 PUSH-LOC TO 3/8 MPT STR ADAPTOR	8
15	34423	BRASS PIPE TEE 3/8 NPT	2
16	516550	FLOW CONTROL VALVE 3/8	2
17	512823	BRASS PIPE CLOSE NIPPLE 3/8 NPT	4
18	34451	BRASS 90° STREET ELBOW 3/8 NPT	8
19	515432	270 ° ROTARY ACTUATOR 2 RACK	1
20	512616	HD-PRT ACTUATOR MOUNT PLATE (5.50 PROBE)	1
21	512475	HD-PRT PROBE ACTUATOR COUPLER	1
22	519458	LIMIT SWITCH BRACKET	1
23	519459	LIMIT SWITCH GUARD	1
24	512471	HD-PRT DRIVE BEARING (5.50 PROBE)	2
25	519460	HD-PRT DRIVE PLATE (5.50 PROBE)	1
26	519461	HD-PRT GUIDE ROD BUSHING 1.25 DIA	2
27	516548	HD-PRT DRIVE PL FLG BEARING (5.50 PROBE)	2
28	516768	HD-PRT LOCK COLLAR (5.50 PROBE)	1
29	516549	5.50 SHAFT RETAINING RING (5.50 PROBE)	1
30	512470	HD-PRT DRIVE TUBE SUPPORT BEARING	2
31	523112	HD-PRT DRIVE SEAL (5.50 PROBE)	1
32	522352	SHOCK ABSORBER SQUARE FLANGE MOUNT	2
33	518979	HD-PRT SHEAR NOSE LOCATOR (5.50 PROBE)	1
34	518980	HD-PRT SHEAR NOSE BEARING (5.50 PROBE)	1
35A	518875	HD-PRT SHEAR NOSE(WOOD CHIPS) (5.50 PROBE)	A/R
35B	522449	CHISEL NOSE (HARD MATERIALS) (5.50 PROBE)	A/R
36	519462	HD-PRT MOUNT PLATE (5.50 PROBE)	1
37	522353	SHOCK ABSORBER STRIKER CAP	2
38	519463	1.250 SHAFT RETAINING RING	4
39	28149	ROD COUPLER 3/4-16 UNF (5.50 PROBE)	2
40	512607	SHOCK ABSORBER	2
41	514487	RUBBER BUMPER	2
42	26402	LIMIT SWITCH NEMA 4, 12	4
43	35341	LIMIT SWITCH ROLLER ARM	2
44	35355	LIMIT SWITCH ARM 13" ROD LEVER	2
45	34185	DOORTITE SEAL 3/16 X 3/4	A/R
46	24550	3/8 ID AIR HOSE	A/R
47	36636	1/2 ID AIR HOSE	A/R
48	528064	3/4 NPT MANIFOLD FOR VALVE	2
49	535963	HD-PRT AIR VALVE MOUNT	1

7.4.1 Sampler Parts Listing HD-PRT w/ 5.50" dia Probe (see Figures 7-1 & 7-2)

ITEM NO.	DESC	QTY	HD-PRT-12	HD-PRT-18	HD-PRT-24
			(12" STROKE)	(18" STROKE)	(24" STROKE)
51	5 BORE AIR CYLINDER	2	526241	526242	526243
52	HD-PRT SS GUIDE ROD	2	519509	519510	519511
53	HD-PRT DRIVE TUBE	1	519517	519518	519519
54	HD-PRT PROBE	1	519525	519526	519527
55	HD-PRT COVER BOTTOM	1	519533	519534	519535
56	HD-PRT COVER TOP	2	519541	519542	519543
57	HD-PRT HOUSING	1	535941	535942	535943
58	HD-PRT HOPPER	1	519464	519465	519466
59	HD-PRT PROBE COVER	1	535965	535966	535967

ITEM NO.	DESC	QTY	HD-PRT-30	HD-PRT-36	HD-PRT-42
			(30" STROKE)	(36" STROKE)	(42" STROKE)
51	5 BORE AIR CYLINDER	2	526244	526245	526246
52	HD-PRT SS GUIDE ROD	2	519512	519513	519514
53	HD-PRT DRIVE TUBE	1	519520	519521	519522
54	HD-PRT PROBE	1	519528	519529	519530
55	HD-PRT COVER BOTTOM	1	519536	519537	519538
56	HD-PRT COVER TOP	2	519544	519545	519546
57	HD-PRT HOUSING	1	535944	535945	535946
58	HD-PRT HOPPER	1	519467	519468	519469
59	HD-PRT PROBE COVER	1	535968	535969	535970

ITEM NO.	DESC	QTY	HD-PRT-48	HD-PRT-54
			(48" STROKE)	(54" STROKE)
51	5 BORE AIR CYLINDER	2	526247	526248
52	HD-PRT SS GUIDE ROD	2	519515	519516
53	HD-PRT DRIVE TUBE	1	519523	519524
54	HD-PRT PROBE	1	519531	519532
55	HD-PRT COVER BOTTOM	1	519539	519540
56	HD-PRT COVER TOP	2	519547	519548
57	HD-PRT HOUSING	1	535947	535948
58	HD-PRT HOPPER	1	519470	519471
59	HD-PRT PROBE COVER	1	535971	535972

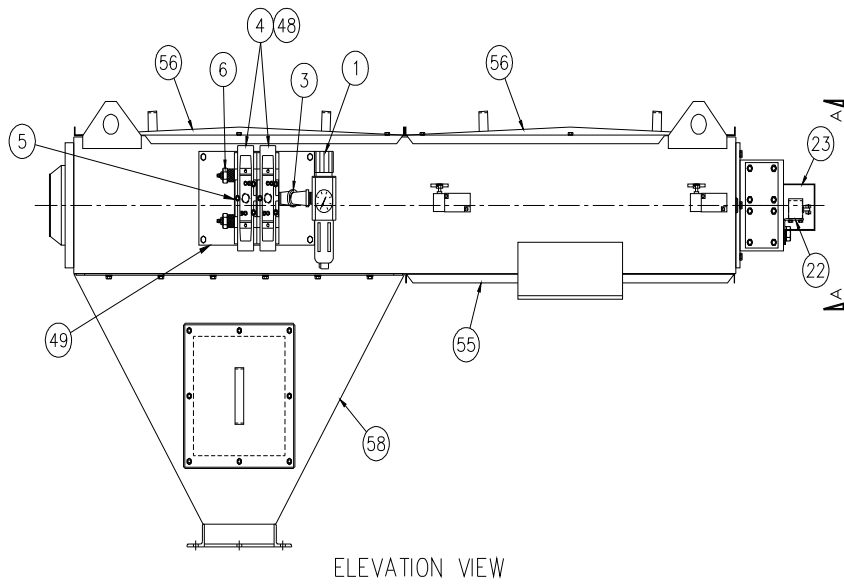
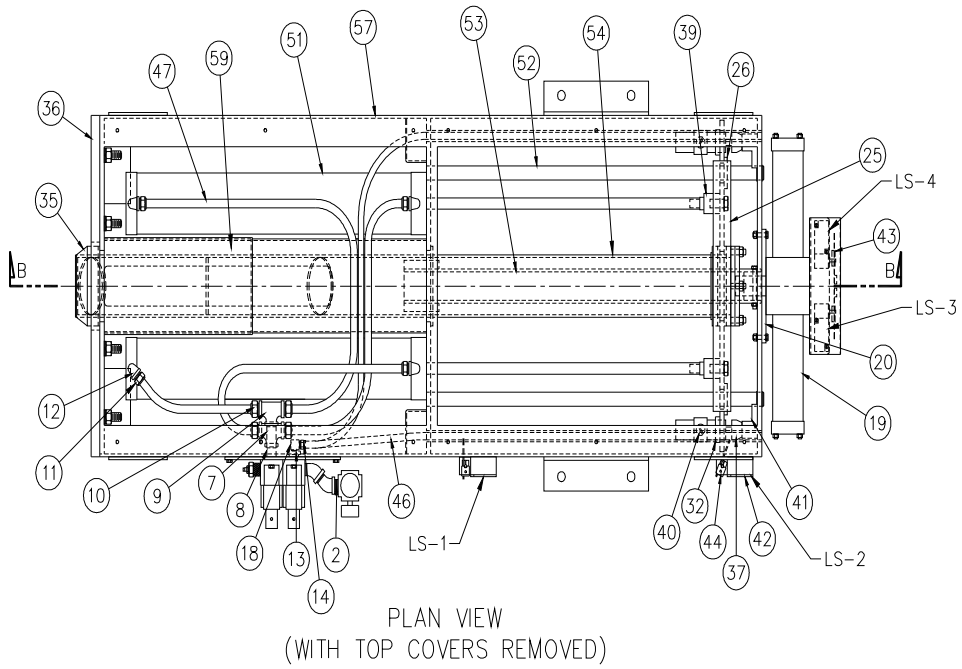

FIGURE 7-1, HD-PRT SAMPLER w/ 5.5"od PROBE

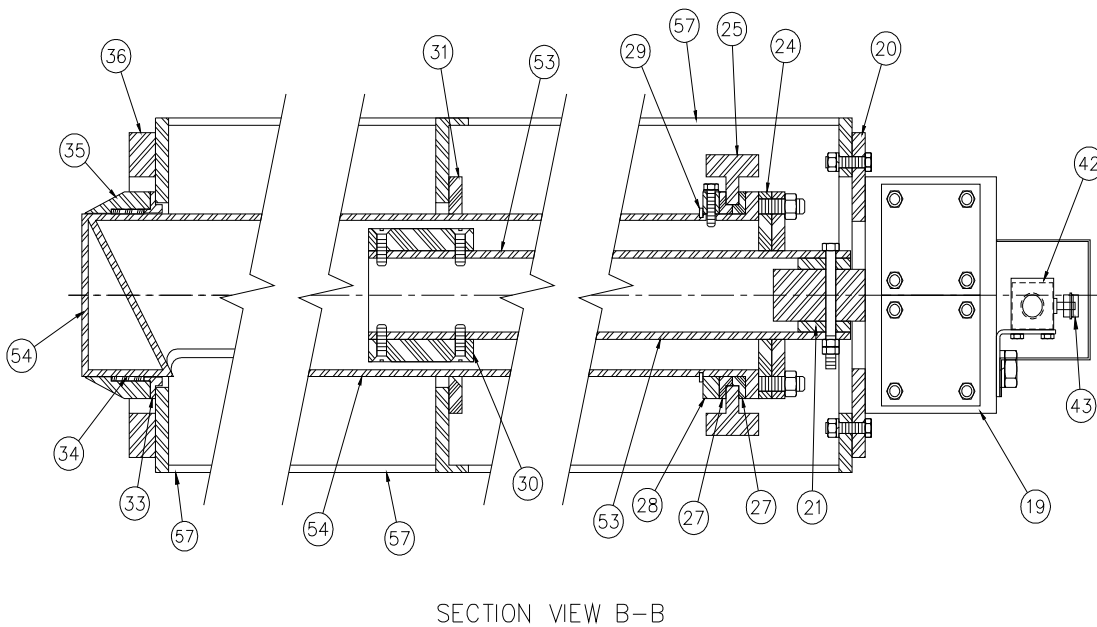
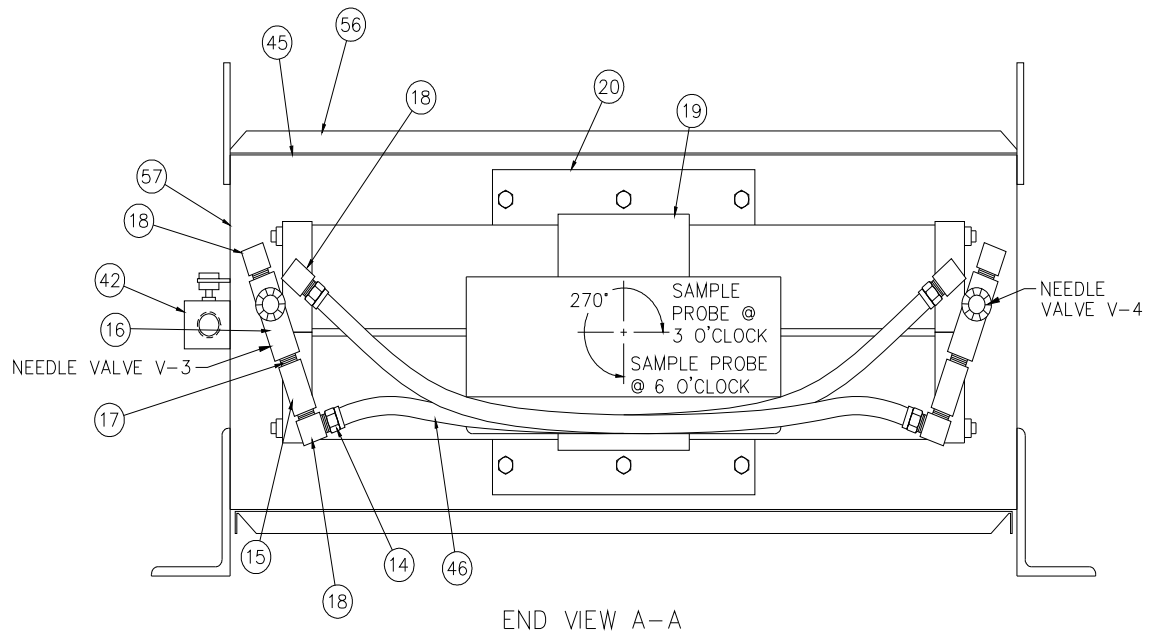

FIGURE 7-2, HD-PRT SAMPLER w/ 5.5"od PROBE

7.4.2 Sampler Parts Listing HD-PRT w/ 8.50" dia Probe (see Figures 7-3 & 7-4)

ITEM NO.	PART NO	DESCRIPTION	QTY
1	519457	3/4 NPT FILTER REGULATOR	1
2	512825	BRASS PIPE CLOSE NIPPLE 3/4 NPT	1
3	35681	BLACK 45° STREET ELBOW 3/4 NPT	2
4	513757	4-WAY NPT SOLENOID VALVE 110/120 VAC 50/60 Hz	2
5	34517	BLACK PIPE PLUG 3/4	7
6	36433	SPEED CONTROL 3/4 NPT	2
7	513801	BLACK PIPE NIPPLE 3/4 X 4	1
8	36441	BLACK PIPE NIPPLE 3/4 X 3	1
9	36442	BLACK PIPE TEE 3/4 NPT	2
10	24567	3/4 PUSH-LOC TO 3/4 MPT STR ADAPTOR	8
11	524594	HD-PRT SUPPORT BEARING SPACER	4
12	35943	BLACK 90° STREET ELBOW 3/4 NPT	4
13	25871	PIPE BUSHING 3/4 X 1/2	4
14	24558	1/2 PUSH-LOC TO 1/2 MPT STR ADAPTOR	4
15	23852	2.00 SHAFT RETAINING RING	2
16	525434	FLOW CONTROL VALVE 1/2	2
17	512824	BRASS PIPE CLOSE NIPPLE 1/2 NPT	2
18	513290	BRASS 90° STREET ELBOW 1/2 NPT	4
19	525384	270° ROTARY ACTUATOR	1
20	525417	HD-PRT ACTUATOR MOUNT PLATE (8.50 PROBE)	1
21	525385	HD-PRT PROBE ACTUATOR COUPLER (8.50 PROBE)	1
22	525386	LIMIT SWITCH BRACKET (8.50 PROBE)	1
23	525387	LIMIT SWITCH GUARD (8.50 PROBE)	1
24	524590	HD-PRT DRIVE BEARING (8.50 PROBE)	2
25	524591	HD-PRT DRIVE PLATE (8.50 PROBE)	1
26	519461	HD-PRT GUIDE ROD BUSHING 1.25 DIA	2
27	524592	HD-PRT DRIVE PL FLG BEARING (8.50 PROBE)	2
28	524593	HD-PRT LOCK COLLAR (8.50 PROBE)	1
29	522412	8.50 SHAFT RETAINING RING	1
30	512470	HD-PRT DRIVE TUBE SUPPORT BEARING	2
31	524595	HD-PRT DRIVE SEAL (8.50 PROBE)	1
32	522352	SHOCK ABSORBER SQUARE FLANGE MOUNT	2
33	524596	HD-PRT SHEAR NOSE LOCATOR (8.50 PROBE)	1
34	524597	HD-PRT SHEAR NOSE BEARING (8.50 PROBE)	1
35A	524598	HD-PRT SHEAR NOSE(WOOD CHIPS) (8.50 PROBE)	A/R
35B	524599	CHISEL NOSE (HARD MATERIALS) (8.50 PROBE)	A/R
36	524600	HD-PRT MOUNT PLATE (8.50 PROBE)	1
37	522353	SHOCK ABSORBER STRIKER CAP	2
38	519463	1.250 SHAFT RETAINING RING	4
39	524589	ROD COUPLER 1-14 UNF (8.50 PROBE)	2
40	512607	SHOCK ABSORBER	2
41	514487	RUBBER BUMPER	2
42	26402	LIMIT SWITCH NEMA 4, 12	4
43	35341	LIMIT SWITCH ROLLER ARM	2
44	35355	LIMIT SWITCH ARM 13" ROD LEVER	2
45	34185	DOORTITE SEAL 3/16 X 3/4	A/R
46	36636	1/2 ID AIR HOSE	A/R
47	36452	3/4 ID AIR HOSE	A/R
48	528064	3/4 NPT MANIFOLD FOR VALVE	2
49	535963	HD-PRT AIR VALVE MOUNT	1

7.4.2 Sampler Parts Listing HD-PRT w/ 8.50" dia Probe (see Figures 7-3 & 7-4)

ITEM NO.	DESC	QTY	HD-PRT-12	HD-PRT-18	HD-PRT-24
			(12" STROKE)	(18" STROKE)	(24" STROKE)
51	6 BORE AIR CYLINDER	2	527822	527823	527824
52	HD-PRT SS GUIDE ROD	2	524665	524666	524667
53	HD-PRT DRIVE TUBE	1	519517	519518	519519
54	HD-PRT PROBE	1	524609	524610	524611
55	HD-PRT COVER BOTTOM	1	524633	524634	524635
56	HD-PRT COVER TOP	2	524625	524626	524627
57	HD-PRT HOUSING	1	535949	535950	535951
58	HD-PRT HOPPER	1	524641	524642	524643
59	HD-PRT PROBE COVER	1	535973	535974	535975

ITEM NO.	DESC	QTY	HD-PRT-30	HD-PRT-36	HD-PRT-42
			(30" STROKE)	(36" STROKE)	(42" STROKE)
51	6 BORE AIR CYLINDER	2	527825	527826	527827
52	HD-PRT SS GUIDE ROD	2	524668	524669	524670
53	HD-PRT DRIVE TUBE	1	519520	519521	519522
54	HD-PRT PROBE	1	524612	524613	524614
55	HD-PRT COVER BOTTOM	1	524636	524637	524638
56	HD-PRT COVER TOP	2	524628	524629	524630
57	HD-PRT HOUSING	1	535952	535953	535954
58	HD-PRT HOPPER	1	524644	524645	524646
59	HD-PRT PROBE COVER	1	535976	535977	535978

ITEM NO.	DESC	QTY	HD-PRT-48	HD-PRT-54
			(48" STROKE)	(54" STROKE)
51	6 BORE AIR CYLINDER	2	527828	527829
52	HD-PRT SS GUIDE ROD	2	524671	524672
53	HD-PRT DRIVE TUBE	1	519523	519524
54	HD-PRT PROBE	1	524615	524616
55	HD-PRT COVER BOTTOM	1	524639	524640
56	HD-PRT COVER TOP	2	524631	524632
57	HD-PRT HOUSING	1	535955	535956
58	HD-PRT HOPPER	1	524647	524648
59	HD-PRT PROBE COVER	1	535979	535980

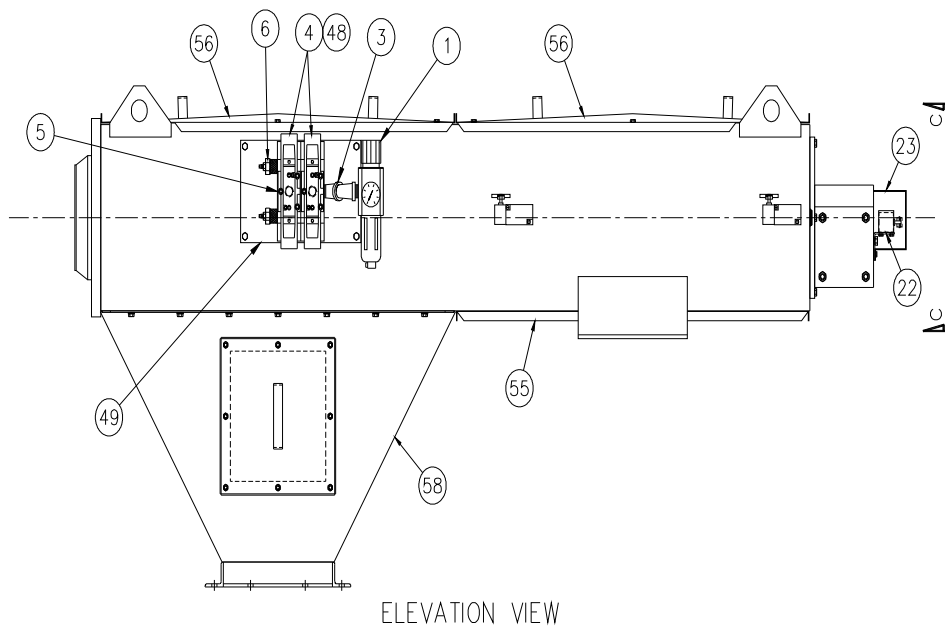
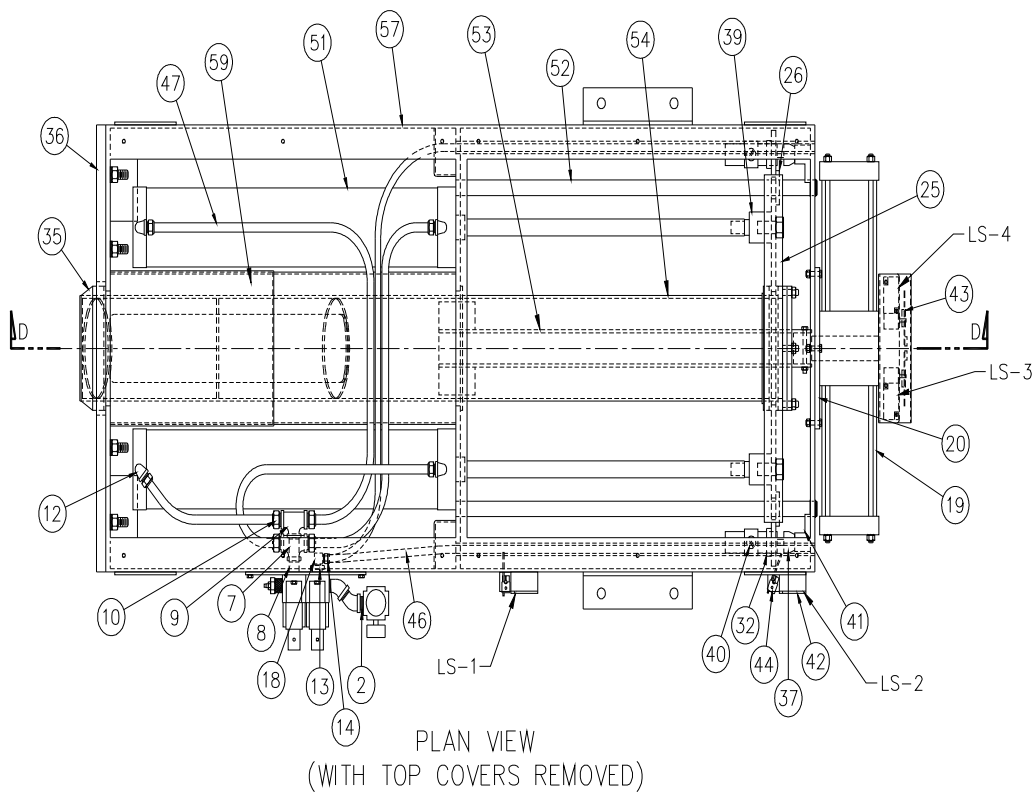

FIGURE 7-3, HD-PRT SAMPLER w/ 8.5"od PROBE

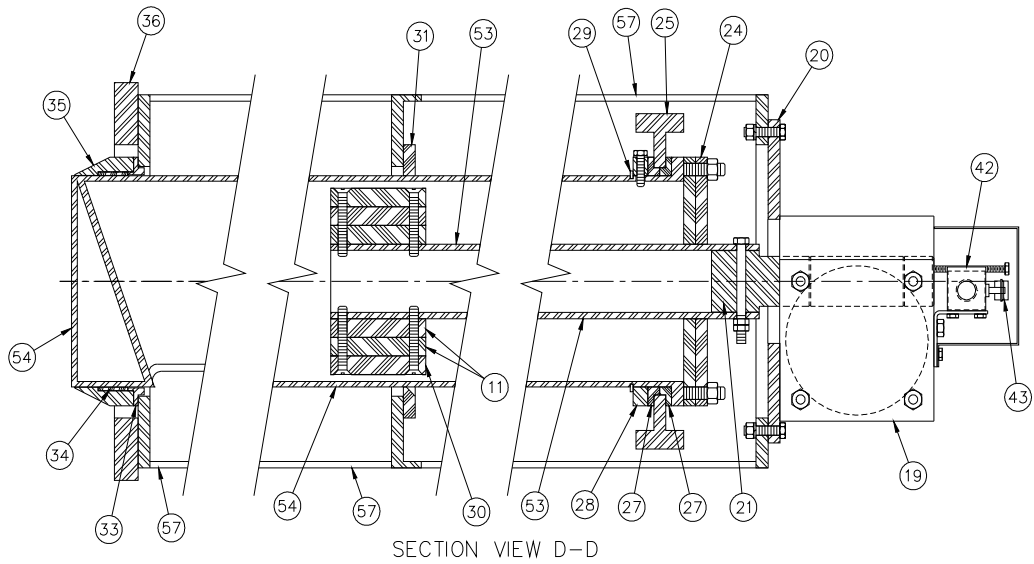
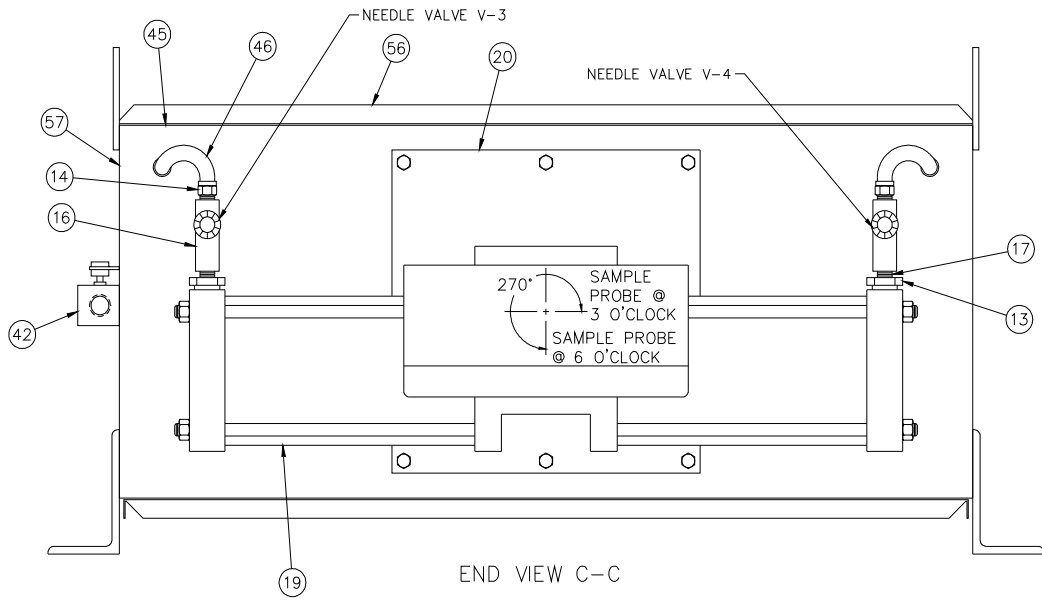

FIGURE 7-4, HD-PRT SAMPLER w/ 8.5"od PROBE

VIII. WARRANTY

Intersystems reserves the right to make changes in design or in construction of equipment and components without obligation to incorporate such changes in equipment and components previously ordered.

WARRANTY, LIMITATION OF LIABILITY, DISCLAIMER OF IMPLIED WARRANTIES: Intersystems manufactured equipment and components are guaranteed against defects in workmanship or materials for one year from date of shipment. The obligation of Intersystems with respect to any goods is limited to replacement or repair of defective parts and equipment provided those parts are returned, shipping costs prepaid, to Intersystems' factory and provided the product has not been subject to misuse, negligence, or accident, or repaired or altered outside of our factory, or other than by an Authorized Service Representative. This warranty does not cover the replacement of parts inoperative because of wear occasioned by use, the cost of replacing parts by a person other than an Intersystems employee or an Authorized Service Representative, or the adjustment of a product where the product was improperly adjusted by the purchaser. In addition, this warranty does not cover components manufactured by others such as motors, drives, clutches, cylinders, valves, blowers, and the like. On those components the standard Manufacturers' warranty applies. In any event, liability is limited to the purchase price paid, and Intersystems will, under no circumstances, be responsible for special or consequential damages, or for incidental damages.

INTERSYSTEMS NEITHER MAKES NOR AUTHORIZES ANY WARRANTY OTHER THAN AS HEREIN CONTAINED. THIS WARRANTY IS IN LIEU OF ALL OTHER WARRANTIES, EXPRESS OR IMPLIED, INCLUDING THOSE OF MERCHANTABILITY AND FITNESS FOR A PARTICULAR PURPOSE.