

intersystems

Model HD-PP Sampler Manual

Safety

Installation

Operation

Maintenance

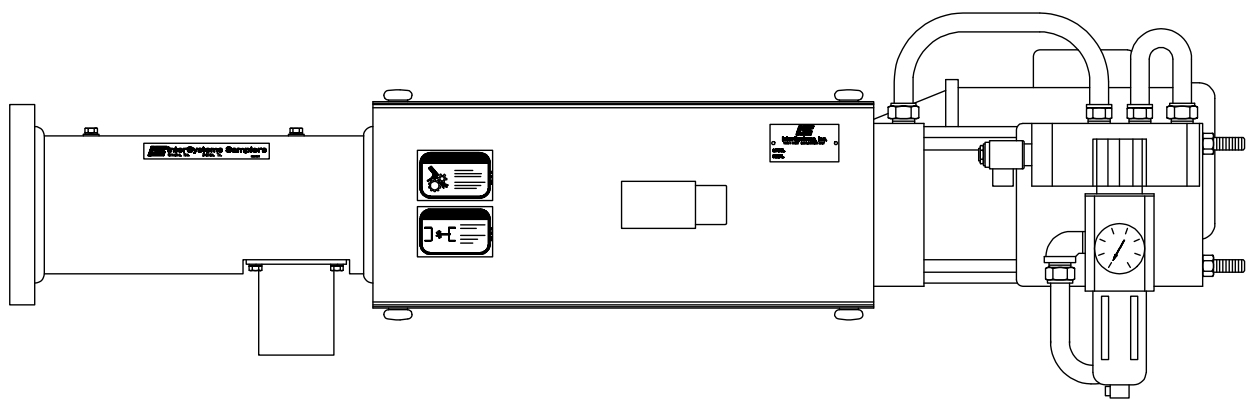

Table of Contents

I. GENERAL SAFETY INFORMATION	3
II. GENERAL INFORMATION	5
2.1 System Description	5
2.2 Optional Features	6
2.3 Material Sampled	6
2.4 Sampler Construction	6
III. GENERAL INSTALLATION REQUIREMENTS	7
3.1 Receiving Inspection	7
3.2 Pre-Installation Preparation	7
3.3 Location	7
3.4 General Mounting Guidelines	7
3.4.1 Sampler Without Optional Mounting Accessories	8
3.4.2 Factory Pre-Mounted Sampler	8
3.4.3 Field-Mounted Sampler Using Weld-On Plates	9
3.4.4 Field-Mounted Sampler Using Clamp-Type Mounting Brackets	9
3.5 Material Sample Transport Lines	10
3.6 Controller Location	10
3.7 System Wiring	11
3.7.1 Electrical Power Requirements, System	11
3.7.1.1 Controller	11
3.7.1.2 Solenoid Valve Coil	11
3.7.1.3 Auger Drive Motor	11
3.8 System Piping	11
3.8.1 Compressed Air Consumption	12
IV. OPERATIONS AND ADJUSTMENTS	13
4.1 Control Components And Their Functions	13
4.1.1 POWER OFF/ON Switch S-2	14
4.1.2 SAMPLING MODE Switch S-3 (Automatic/Manual)	14
4.1.3 MANUAL SAMPLING Switch S-4	14
4.1.4 POWER Pilot Light	14
4.1.5 SAMPLING Pilot Light	14
4.1.6 Digital Display Timer T-1 (Standard)	15
4.1.7 Digital Display Counter C-1 (Optional)	16
4.1.8 Printed Circuit Board	16
4.1.8.1 Main Fuse	17
4.1.8.2 Motor Fuse	17
4.1.8.3 PC Board Fuse F3	17
4.1.8.4 Motor Timer Switches (Tens & Ones)	17
4.1.8.5 Solenoid Timer Switches (Tens & Ones)	18
4.1.8.6 Motor LED Indicator	18
4.1.8.7 Solenoid LED Indicator	18
4.1.8.8 Mode Select Switch	18
4.1.8.9 Terminal Strip	19
4.1.8.10 115V/230V Switch	19
4.2 Sampler Mounted Electrical Components	20
4.2.1 Limit Switch, LS-1	20
4.2.2 Auger Drive Motor	20
4.3 Pneumatic Components	21
4.3.1 Solenoid Valve V-1	21
4.3.2 Needle Valve (Optional)	21
4.3.3 Purge Solenoid Valve V-2 (Optional)	21
4.3.4 Air Filter/Pressure Regulator	23

4.3.5 Pneumatic Cylinder.....	23
V. MAINTENANCE AND REPAIR	24
5.1 General Maintenance	24
5.2 Periodic Inspection	24
5.3 Lubrication	24
5.3.1 Auger Bevel Gears	24
5.3.2 Airline Lubricator	25
5.4 Draining and Servicing the Filter.....	25
5.5 Mechanical Repair Procedures.....	25
5.5.1 Adjustment of Seal Pressure	25
5.5.2 Seal Replacement	26
5.5.3 Sample Probe, Auger And Seal Replacement.....	27
5.5.4 Bevel Gears Replacement.....	28
VI. TROUBLESHOOTING	30
6.1 General HD-PP Sampler Troubleshooting.....	30
6.2 PC Board Troubleshooting	32
6.3 Directional Solenoid Valve Troubleshooting	33
6.4 Air Components Troubleshooting	34
6.4.1 Cylinder Leaking	34
6.4.2 Valve vs. Cylinder Leak Test	35
VII. REPLACEMENT PARTS	36
7.1 Scope.....	36
7.2 Ordering Parts	36
7.3 Replacement Parts	36
7.4 Repair Kits	36
VIII. WARRANTY.....	43

List Of Illustrations & Drawings

FIGURE 1-1, HD-PP SAMPLER SAFETY LABEL LOCATIONS.....	4
FIGURE 2-1, TYPICAL INSTALLATION, MODEL HD-PP SAMPLING SYSTEM.....	5
FIGURE 3-1, PNEUMATIC SCHEMATIC.....	12
FIGURE 4-1, STANDARD NEMA 4 CONTROL PANEL DETAIL.....	13
FIGURE 4-2, PRINTED CIRCUIT BOARD.....	17
FIGURE 4-3, LIMIT SWITCH CONNECTIONS.....	20
FIGURE 4-4, SOLENOID VALVE.....	21
FIGURE 4-5, OPTIONAL PURGE CONFIGURATIONS	22
FIGURE 4-6, FILTER/REGULATOR	23
FIGURE 5-1, BEVEL GEAR ALIGNMENT	29
FIGURE 6-1, CONDENSED MOISTURE BLOCKING AIRLINE	33
FIGURE 6-2, VALVE VS. CYLINDER LEAK TEST DIAGRAM	35
FIGURE 7-1, TEFLON SEAL AND SPACER ARRANGEMENTS.....	37
DRAWING 525004, HD-PP-6 SECTION VIEW & PARTS LIST	38
DRAWING 525005, HD-PP-8 SECTION VIEW & PARTS LIST	39
DRAWING 525006, HD-PP-10 SECTION VIEW & PARTS LIST	40
DRAWING 525007, HD-PP-12 SECTION VIEW & PARTS LIST	41
DRAWING 525011, HD-PP MOTOR CONFIGURATION VIEW.....	42

I. GENERAL SAFETY INFORMATION

SAFETY FIRST! The symbols shown identify examples of the safety labels and signs to be found on Intersystems equipment. They are affixed to the equipment to warn of danger to persons and of possible equipment damage. These signs must never be removed, tampered with, painted over or obscured in any way. (See Page 4 for label locations.) If labels are damaged or become unreadable, replacement labels are available from Intersystems. The user must institute a continuing program to instruct all personnel in safe operating and maintenance procedures, and to insure that all safety devices, guards, and covers are intact and operable, and that all safety signs are legible.

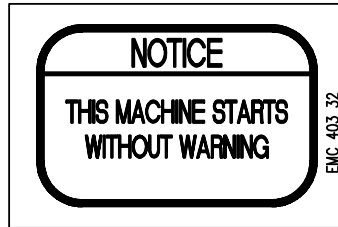

STARTS W/OUT WARNING
EMC40332

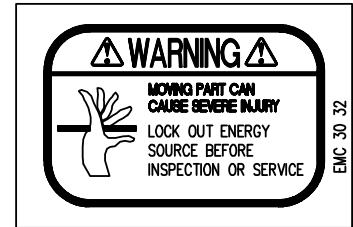

MOVING PART
EMC3032

Consult Intersystems before making any changes to the sampler or its operating environment. Careless changes could result in death or serious injury to people, and reduce the performance and service life of the equipment.

Never perform any service on this equipment or any other powered equipment until all power has been shut off and locked out so that it cannot be restored without the consent and knowledge of the person who interrupted power. Power includes electrical, fluid, mechanical, or pneumatic energy.

Never perform any service on this equipment without utilizing the required PPE (personal protective equipment). Refer to the MSDS(s), material safety data sheet(s), on all the products to which this equipment is in contact with to determine what PPE is required.

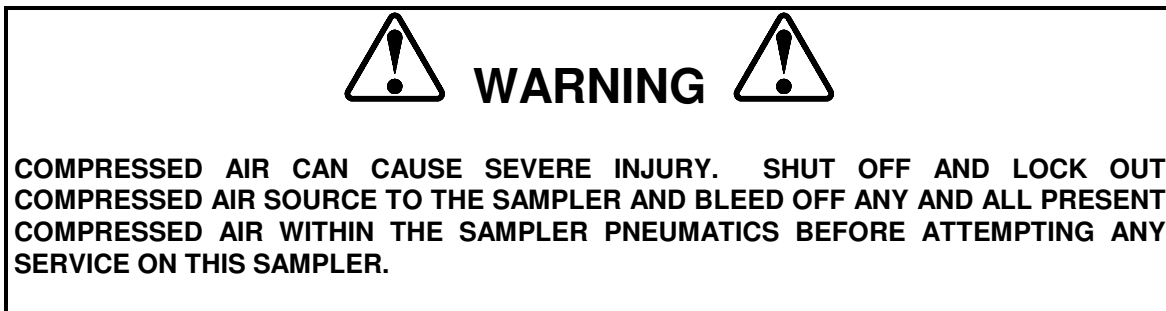
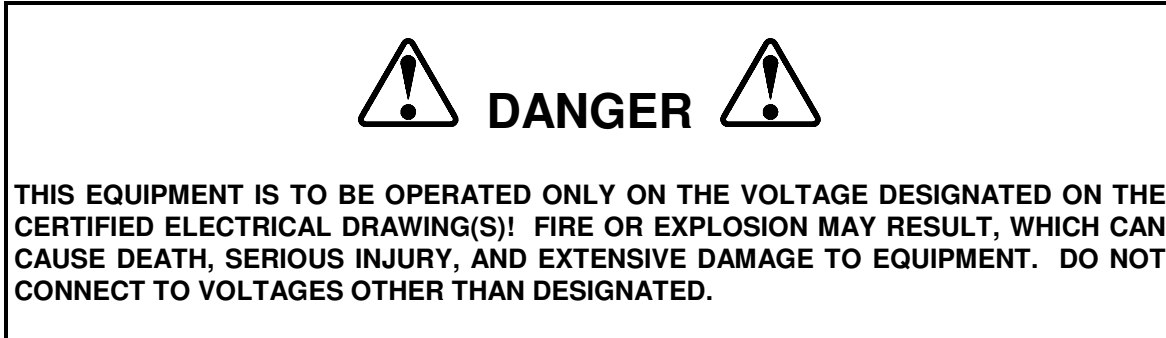

NOTE: THESE SIGNS MUST NEVER BE REMOVED, TAMPERED WITH, PAINTED OVER, OR OBSCURED IN ANY WAY. IF LABELS ARE DAMAGED OR BECOME UNREADABLE, REPLACEMENT LABELS ARE AVAILABLE FROM INTERSYSTEMS.

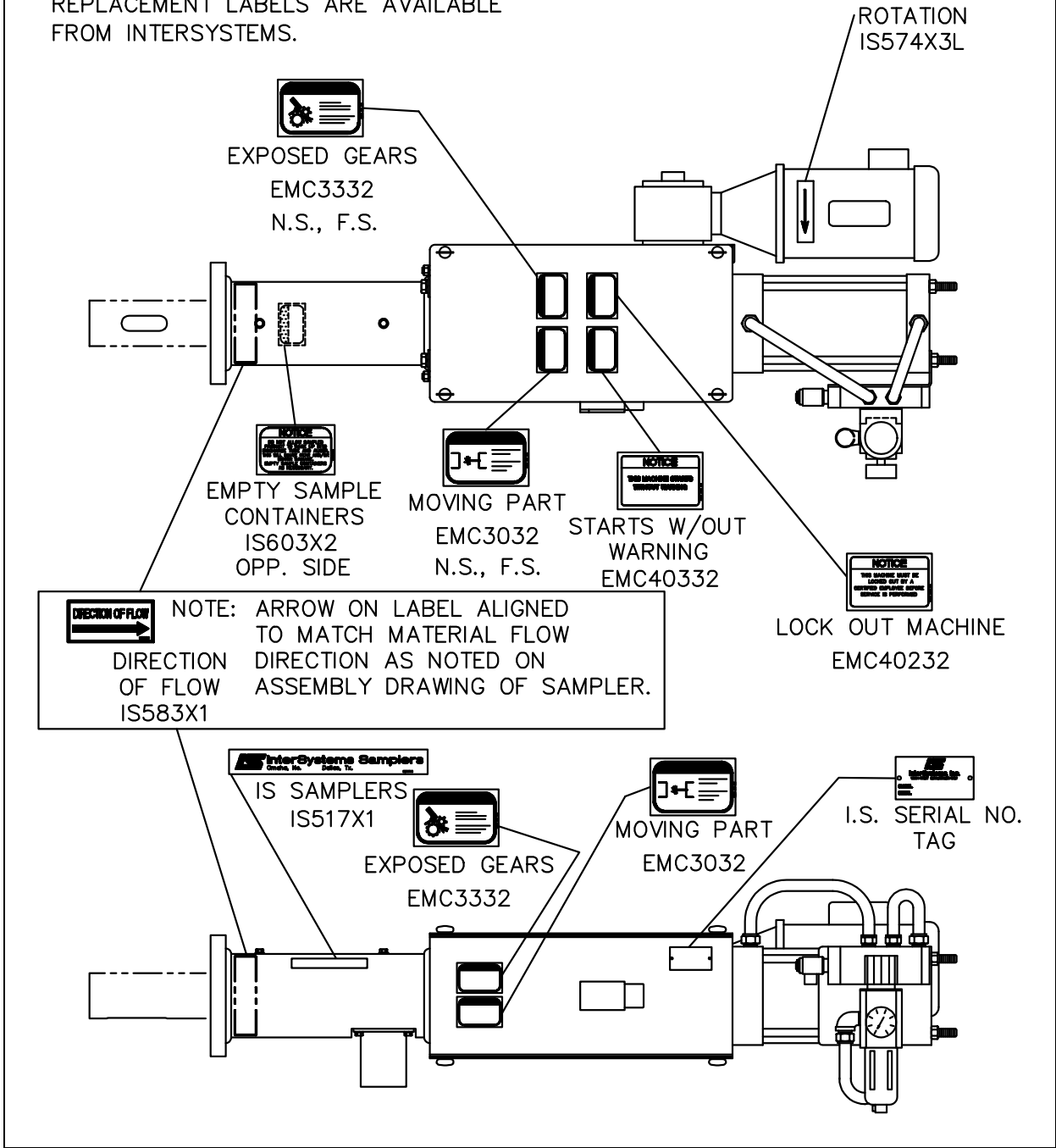

FIGURE 1-1, HD-PP SAMPLER SAFETY LABEL LOCATIONS

II. GENERAL INFORMATION

2.1 System Description

The HD-PP Sampler is designed to collect a representative sample of granular, flake, powder, or other materials in a gravity or pressurized conveying line or from a hopper tank or pressure vessel. Figure 2-1 illustrates a typical HD-PP Sampler application.

Sample collection is initiated in response to either an operator's manual command or a signal automatically generated by controller logic, usually time-based but which could also be volume or quantity based. A sample cycle begins when a double-acting pneumatic cylinder forces the slotted sampling tube (probe) into the product line to collect a sample of the material. Next, the sample tube probe is withdrawn into the seal housing isolating the sample and sample tube cavity from the conveying line. Then, an electric motor operating through a set of bevel gears, rotates the auger through several revolutions, augering the sample collected to the 3.00" (76mm) OD discharge outlet tube. The sample then falls down and out the discharge tube to the desired sample collection point, at which point an Intersystems SCS Sample Collection System (optional) may be installed.

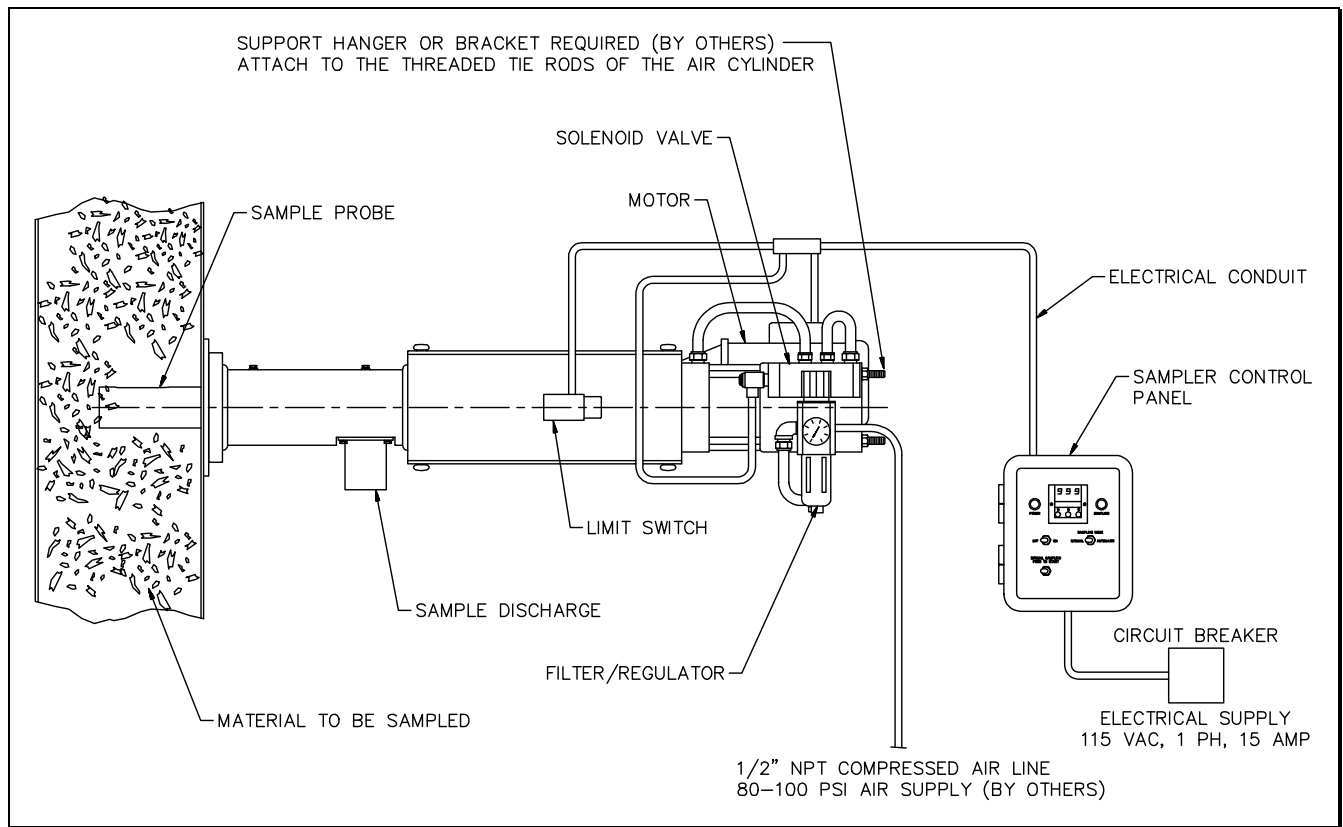

FIGURE 2-1, TYPICAL INSTALLATION, MODEL HD-PP SAMPLING SYSTEM

2.2 Optional Features

The certified drawings indicate which, if any, optional features are included with a sampling system. Some of the more frequently specified optional features are briefly described in the following list.

- A. Controller arranged to initiate a sampling cycle based on quantity or volume of material passing through conveying line rather than upon elapsed time periods.
- B. Explosion-Proof Sampling System. There are several major differences in an explosion-proof sampler as compared to a standard sampling system. An explosion proof sampler will typically have the following features.
 - 1. An explosion-proof solenoid on the directional control valve with the rating of:
 - Class 1, Groups C & D, Division 1 & 2
 - Class 2, Groups E, F & G, Division 1 & 2
 - 2. An explosion-proof limit switch with the rating of:
 - Class 1, Groups C & D, Division 1 & 2
 - Class 2, Groups E, F & G, Division 1 & 2
 - 3. An explosion-proof motor with the rating of:
 - Class 1, Groups D, Division 1 & 2
 - Class 2, Groups E, F & G, Division 1 & 2

The explosion proof sampler control is available in two enclosure classifications.

- 1. The NEMA 9 control with the rating of:
 - Class 2, Groups E, F & G, Division 1 & 2
 - 2. The NEMA 7 control with the rating of:
 - Class 1, Groups C & D, Division 1 & 2
 - Class 2, Groups E, F & G, Division 1 & 2
- C. Purge air systems to either aid in material discharging from the sampler or to prevent material from building up in v-ring packing seals.
- D. Components of special materials, such as 316 stainless steel, monel, inconel or nedox coatings.
- E. Programmable Controls to sequence the sampler and the sample collection equipment.

2.3 Material Sampled

Most materials from light to heavy density powders, granules, flakes, viscous liquids and slurries.

2.4 Sampler Construction

Standard sampler housing construction is of painted aluminum. The sample probe, auger, gear housing and covers are of Type 304 Stainless Steel. The auger is 2-1/2" OD, machined from a solid bar (no welds on flights) and hand polished. Other materials and/or finishes appropriate to the operating environment and the material or product being sampled may be used. Refer to the certified drawing(s) for any optional or special components installed on the sampler.

III. GENERAL INSTALLATION REQUIREMENTS

3.1 Receiving Inspection

Carefully inspect the sampling system for damage as soon as it is received. Also verify that the quantity of parts or packages actually received corresponds to the quantity shown on the packing slip. Report any damage or shortage to the delivering carrier as soon as possible. Intersystems' responsibility for the equipment ended with acceptance by the delivering carrier. Refer to the bill of lading.

3.2 Pre-Installation Preparation

Note, before starting sampling system installation, study this manual, the certified drawing(s) furnished with the system, and other applicable documents (including, but not limited to OSHA Regulations; the National Electrical Code; and all other applicable federal, state, and local codes and regulations).



3.3 Location

The HD-PP sampler is typically mounted horizontally onto a vertical or horizontal conveying line carrying the product to be sampled as in Figure 2-1. The sampler axis must be installed perpendicular (at a 90 degree angle) to the axis of the product line for optimum performance. Additionally, the sampler should be located where the product has a non-turbulent flow pattern. The sampler and associated equipment should be located for ease of access and maintenance.

The sampler is to be installed only as shown on the certified drawing(s). If an alternate mounting arrangement is desired, contact Intersystems prior to installation for proper guidance. The sampler is of a general design with modifications specifically for your application. It may be necessary to rework the sampler in order for it to function properly if you alter the application.

3.4 General Mounting Guidelines

The sampler assembly is designed to support ONLY its own weight. As shown on the certified drawing of the sampler, the sampler must be installed with an additional hanger or bracket to rigidly support the sampler. The support can be attached the cylinder tie rods at the rear of the cylinder. The hanger or bracket should be capable of supporting approximately 300 lbs.

**DANGER**
**SAMPLER CANNOT SUPPORT ANY OTHER EQUIPMENT OR CONVEYING LINE!
COLLAPSE OF THE WHOLE SYSTEM CAN CAUSE DEATH, SERIOUS INJURY, AND
EXTENSIVE DAMAGE TO EQUIPMENT. PROPERLY SUPPORT ALL SPOUTS,
CONTAINERS, AND CONVEYING LINES.**

NOTE: IF THE SURFACE AREA TO WHICH THE MOUNTING PLATE IS TO BE ATTACHED IS WARPED OR BENT, STRAIGHTEN AND SMOOTH THE METAL SO THE SAMPLER WILL BE PROPERLY ALIGNED WHEN THE INSTALLATION IS COMPLETE. THE SURFACE TO WHICH THE SAMPLER IS MOUNTED MUST NOT FLEX. THE SAMPLER CYLINDER MUST BE RIGIDLY SUPPORTED; ANY FLEXING WILL DAMAGE THE SAMPLER.

NOTE: OVER TIGHTENING THE MOUNTING FASTENERS WILL WARP OR CRACK THE SEAL HOUSING FLANGE. IMPROPER SAMPLING WILL RESULT.

3.4.1 Sampler Without Optional Mounting Accessories

- A. Locate and mark the desired mounting location on the product line.
- B. Cut and deburr a 3.5" diameter hole in the product line through which the sample tube will pass to collect material samples.
- C. The mounting flange on the end of the seal housing has four .562 (9/16") clearance holes for 1/2" mounting screws or studs. Using the sampler mounting face as a pattern, layout or transfer punch the hole locations onto the conveying line.
- D. Drill and tap the holes for the mounting screws, or weld studs to the conveying line for fastening the sampler.
- E. Ensure that the o-ring is seated in the groove on the sampler housing mounting flange and verify that the sample tube extends and retracts without interference.
- F. Install the sampler on the mount surface and tighten the mounting fasteners to insure proper sealing between the sampler seal housing and the product line.
- G. If the conveying line is a pressure or vacuum line, check to see that the seal at the connection is airtight. Re-tighten fasteners if necessary.
- H. The user or installer must provide a hanger or bracket to rigidly support the sampler. The support can be attached to the cylinder tie rods at the rear of the cylinder. The hanger or bracket should be capable of supporting approximately 300 lbs.

3.4.2 Factory Pre-Mounted Sampler

As furnished, the premounted sampler is already firmly attached to a length of tube, pipe, etc.

- A. Remove a section of pipe or chute work where the sampler is to be installed.
- B. Remove the sampler from the sampler premount.
- C. Locate the sampler premount in the desired position.
- D. Attach the sampler premount using one of the following methods.
 - 1-Weld the sampler premount ends directly to the existing pipe or chute work.
 - 2-Clamp the sampler premount ends to the existing pipe utilizing compression couplings
 - 3-Weld matching flanges to the existing pipe or chute work and sampler premount.
- E. Ensure that the o-ring is seated in the groove on the sampler housing mounting flange.

F. Install the sampler on the mount surface and tighten the mounting fasteners to insure proper sealing between the sampler seal housing and the product line.

G. If the conveying line is a pressure or vacuum line, check to see that the seal at the connections are airtight. Re-tighten fasteners and/or re-weld if necessary.

H. The user or installer must provide a hanger or bracket to rigidly support the sampler. The support can be attached to the cylinder tie rods at the rear of the cylinder. The hanger or bracket should be capable of supporting approximately 300 lbs.

3.4.3 Field-Mounted Sampler Using Weld-On Plates

Weld-on plates are typically used when mounting the sampler to a large existing surface, such as on a storage hopper or a long section of chutework.

A. Locate and mark the desired mounting location on the conveying line.

B. Cut and deburr a 3.5" diameter hole in the conveying line through which the sample tube will pass to collect material samples.

C. Position the sampler mounting plate by aligning the 3.5" diameter sample probe clearance holes.

D. Tack weld the sides of the mounting plate to the product line surface and double check alignment.

E. Weld a continuous bead around all sides of the mounting plate.

NOTE: WHEN WELDING THE MOUNTING PLATE TO THIN GAUGE SHEET OR THIN PLATE, SKIP WELD ALTERNATING SIDES OF THE MOUNTING PLATE TO LIMIT HEAT INPUT TO MINIMIZE WARPING.

F. Ensure that the o-ring is seated in the groove on the sampler housing mounting flange and verify that the sample tube extends and retracts without interference.

G. Install the sampler on the mount surface and tighten the mounting fasteners to insure proper sealing between the sampler seal housing and the product line.

H. If the conveying line is a pressure or vacuum line, check to see that the seals at the connections are airtight. Re-tighten fasteners and/or re-weld if necessary. If the weld leaks, remove the sampler and o-ring before making any repair welds. Weld heat will damage or destroy the gasket and the Teflon seals in the seal housing.

I. The user or installer must provide a hanger or bracket to rigidly support the sampler. The support can be attached to the cylinder tie rods at the rear of the cylinder. The hanger or bracket should be capable of supporting approximately 300 lbs.

3.4.4 Field-Mounted Sampler Using Clamp-Type Mounting Brackets

Clamp-type mounting brackets are used on round tube or pipe conveying lines.

A. Locate and mark the desired mounting location on the conveying line.

B. Cut and deburr a 3.5" diameter hole in the product line through which the sample tube will pass to collect material samples.

C. Make sure the 1/8" thick Neoprene gasket is in place inside the clamp adapter.

D. Position the clamp bracket by aligning the sample probe clearance holes and tighten the clamp fasteners.

NOTE: OVER TIGHTENING THE BRACKET FASTENERS WILL DISTORT THE CONVEYING LINE TUBE OR PIPE. THE TUBE CAN CRACK OR BUCKLE, THE SAMPLER WILL NOT BE PROPERLY ALIGNED WITH THE PRODUCT STREAM, AND IN CASES WHERE THE CONVEYING LINE ID. IS NEARLY THE SAME AS THE STROKE OF THE SAMPLER, THE SAMPLE TUBE MAY ACTUALLY STRIKE THE OPPOSITE SIDE OF THE TUBE AS IT EXTENDS.

E. Ensure that the o-ring is seated in the groove on the sampler housing mounting flange and verify that the sample tube extends and retracts without interference.

F. Install the sampler on the mount surface and tighten the mounting fasteners to insure proper sealing between the sampler seal housing and the product line.

G. If the conveying line is a pressure or vacuum line, check to see that the seal at the mounting clamp is airtight. Tighten clamp fasteners if necessary.

H. The user or installer must provide a hanger or bracket to rigidly support the sampler. The support can be attached to the cylinder tie rods at the rear of the cylinder. The hanger or bracket should be capable of supporting approximately 300 lbs.

3.5 Material Sample Transport Lines

The tubing used to transport material samples must be compatible with the operating environment and the material sampled. Typically a 3.00" ID flexible hose is slipped over the discharge tube and held in place by a worm clamp. The hose is then routed to allow material to flow via gravity to a convenient collection point. At that point the hose may be connected to a collection jar bracket or a Sample Collection System cabinet.

Rigid tubing may also be used if desired for the sample transport line.

Make all connections airtight and make sure all interior surfaces of joints are smooth and flush. Any ragged or raised tube ends will collect dust and debris as well as retard material flow. Air leaks can interfere with the pressure or vacuum conveying and sampling system. Escaping sample material can contaminate surrounding atmosphere and equipment.

3.6 Controller Location

A. Use vibration isolation pads when mounting the control enclosure or mount the controller in a vibration-free location.

B. Unless ordered for severe duty, locate controller so it is protected from water and dust.

C. Unless an explosion-proof rated controller was specifically ordered, DO NOT locate the controller in a hazardous area.

D. Most applications require that the sampler be in easy view of the controller.

3.7 System Wiring

Refer to the certified electrical drawing(s) for specific wiring requirements. As explained in Paragraph 4.1.8.9, the 20-position barrier terminal strip on the circuit board mounted INSIDE the controller enclosure is the connection point for ALL external circuitry.

The controller was completely assembled and tested with the sampler before it left the factory. The electrical installation must comply with OSHA Regulations; the National Electrical Code; and all other applicable federal, state, and local codes and regulations.

If wiring between the controller and the sampler unit is run through rigid conduit, use a short length of flexible conduit to connect wiring to the sampler. This will isolate the rigid conduit from any vibration originating in the product conveying line and sampler.

3.7.1 Electrical Power Requirements, System

110/120 VAC 50/60 Hz, Single Phase, 20 Amp Service.
Optional - 220/240 VAC 50/60 Hz, Single Phase, 10 Amp Service.

Refer to the certified electrical drawing(s) for specific wiring requirements. Intersystems strongly recommends that electrical service to the sampling system be an isolated line. Voltage fluctuations and line noise can affect the controller's circuit board, thus causing the sampler to malfunction.

3.7.1.1 Controller

110/120 VAC, 50/60 Hz, Single Phase, 14 Amp Max. (includes motor power requirements).
Optional - 220/240 VAC, 50/60 Hz, Single Phase, 7 Amp Max. (includes motor power requirements).

3.7.1.2 Solenoid Valve Coil

110/120 VAC, 50/60 Hz, Single Phase, 7 Watts.
Optional - 220/240 VAC, 50/60 Hz, Single Phase, 7 Watts.

3.7.1.3 Auger Drive Motor

Standard 110/120 VAC, 220/240 VAC, 50/60 Hz, Single Phase, 9.8/4.9 Full Load Amps.

3.8 System Piping

NOTE: USE ONLY CLEANED, PICKLED, DESCALED, AND OILED PIPE FOR AIR SUPPLY LINES. DIRT, SCALE, AND DEBRIS USUALLY FOUND IN STANDARD PIPE QUICKLY CLOGS FILTER/REGULATORS, VALVES, ETC. USE ONLY TEFLON TAPE TO SEAL PIPE JOINTS. CAREFULLY APPLY THE TAPE TO PIPE AND FITTINGS SO NO FRAGMENTS ENTER THE SYSTEM.

The pneumatic system was pre-plumbed and tested with the sampler before it left the factory. The final installation must comply with OSHA Regulations and all other applicable federal, state, and local codes and regulations.

As shown on the certified drawing(s), the solenoid valves and filter/regulator (F/R) were mounted on the sampler at the factory. The user or installer must pipe the compressed air supply to the F/R. Minimum pipe size for the air supply to the filter/regulator is 3/4" NPT, reduced to 1/2" NPT at sampler. Larger piping to the sampler, and/or a surge tank located at the sampler, will be required on installations where the compressed air source is further than 200 feet from the sampler to prevent excessive drop in air pressure.

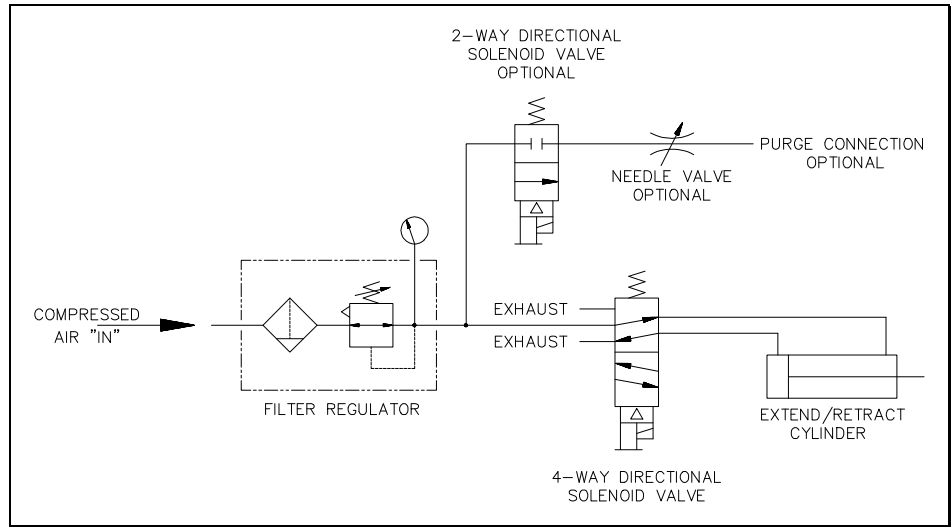

FIGURE 3-1, PNEUMATIC SCHEMATIC

Intersystems recommends installing a shutoff valve upstream of the filter/regulator. A shutoff valve facilitates maintenance as it allows the sampler's pneumatic system to be maintained and repaired without shutting down other equipment supplied from the same air source.

3.8.1 Compressed Air Consumption

A complete sampling cycle requires that the cylinder extend and retract and that the auger motor run the auger for a specified amount of time. To determine the compressed air requirements to operate the sampler, multiply the consumption per cycle (refer to chart) by the number of cycles per minute. The number calculated is the SCFM (Standard Cubic Feet per Minute) of air required. A typical cycle takes between 10-20 seconds, depending on the sampler size and control settings. The regulator cannot increase downstream outlet pressure above the upstream inlet pressure. If the pressure from the regulator is not sufficient to operate the cylinder, some means must be found to increase the inlet pressure to the regulator. Recommended air supply pressure is 80-100 PSI.

MODEL/SIZE	AIR CONSUMPTION PER SAMPLE CYCLE @ 80 PSI
HD-PP-6	1.2 SCF
HD-PP-8	1.6 SCF
HD-PP-10	2.0 SCF
HD-PP-12	2.5 SCF
HD-PP-14	2.9 SCF
HD-PP-16	3.3 SCF
HD-PP-18	3.7 SCF

The pneumatic system on the sampler, consisting of the filter/regulator, directional control valve and air cylinder was pre-plumbed and tested at the factory. The regulator is factory set at 80 PSI.

IV. OPERATIONS AND ADJUSTMENTS



DANGER



FAILURE TO OBSERVE ALL SAFETY RULES, WRITTEN AND IMPLIED, AND THOSE SUGGESTED BY COMMON SENSE, CAN RESULT IN DEATH, SERIOUS INJURY, AND /OR EQUIPMENT DAMAGE. LOCKOUT POWER BEFORE PERFORMING ANY MAINTENANCE.

4.1 Control Components And Their Functions

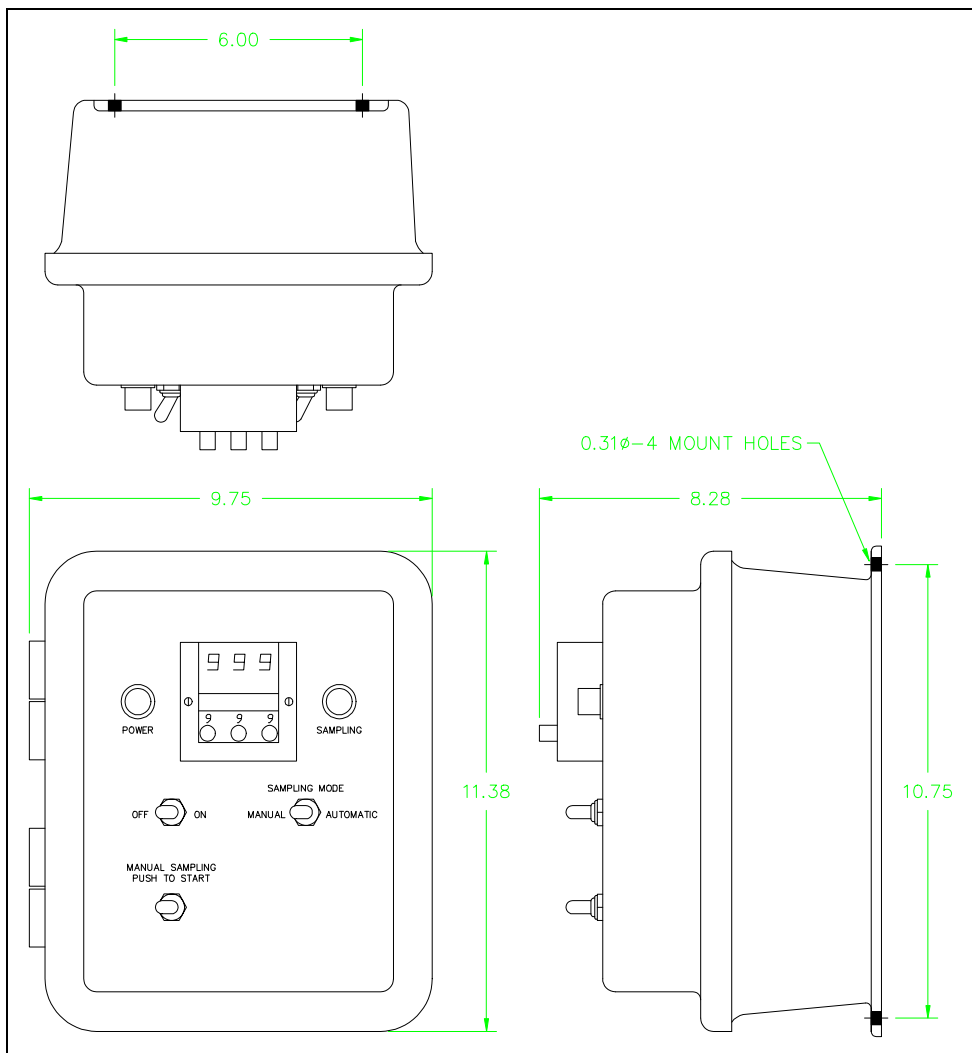
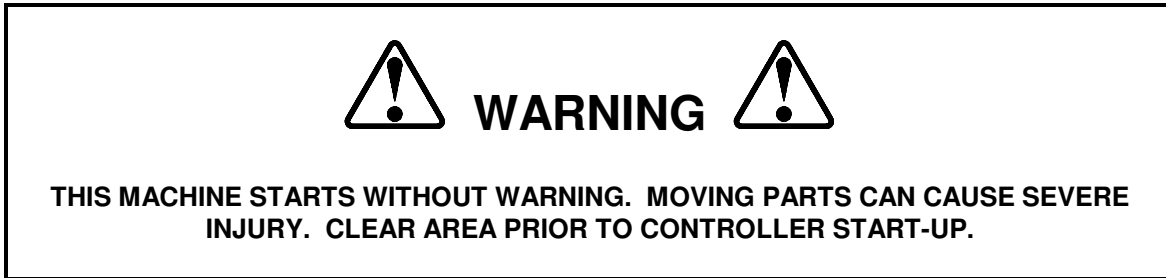

FIGURE 4-1, STANDARD NEMA 4 CONTROL PANEL DETAIL

Refer to the certified electrical drawing(s) for dimensions on control panels with optional features.

4.1.1 POWER OFF/ON Switch S-2

This toggle switch controls all electrical power to the controller and the sampler unit.



4.1.2 SAMPLING MODE Switch S-3 (Automatic/Manual)

This switch permits the operator to select whether samples will be collected automatically at precisely timed or counted intervals as determined by the Digital Display Timer (T-1) or Counter C-1, OR manually whenever the operator momentarily actuates the MANUAL SAMPLING toggle switch (S-4).

4.1.3 MANUAL SAMPLING Switch S-4

This switch functions ONLY when the AUTO/MANUAL switch has been set to the Manual Mode position. Switch S-4 is a spring-return switch that is maintained in the OFF or Normally Open position. Correct operating procedure is to momentarily actuate S-4 to the Start position. When the SAMPLING light is illuminated, release the switch. The sampler will complete its cycle without further operator intervention.

4.1.4 POWER Pilot Light

This light is illuminated as long as power is available to the controller and the POWER switch (S-2) is set to ON.

4.1.5 SAMPLING Pilot Light

This light will illuminate when a sampling cycle has been initiated and will stay lit until the sampling cycle has completed.

NOTE: A 5 SECOND DELAY BETWEEN SAMPLES IS BUILT INTO THE PC BOARD LOGIC. THIS ALLOWS THE DRIVE GEARS TO COAST TO A STOPPED POSITION PRIOR TO UN-MESHING. THE PC BOARD WILL ACCEPT THE SIGNAL TO SAMPLE, (IF ONE IS SENT) FROM EITHER THE TIMER, COUNTER OR MANUAL SAMPLE SWITCH DURING THIS INTERVAL AND INITIATE THE SAMPLE AS SOON AS THIS TIME HAS ELAPSED.

4.1.6 Digital Display Timer T-1 (Standard)

As arranged for use in this system, the timer operates in the DOWN & STOP mode. When the AUTO mode is selected, the illuminated display resets to the value dialed in to the Three Digit Preset. Immediately, the timer begins timing down. When the illuminated display reads all zeroes (000), the timer has "timed out" and initiates a sampling cycle. The sample probe extends and delays to collect a sample, then retracts at which time the limit switch LS-1 is actuated, then the auger motor is energized for an interval of time and the timer T-1 is reset (powered off), then the motor stops, and the timer display resets to the preset value and another timing interval is initiated. If the controller is shut off or the mode switched from AUTO to MANUAL, the timing cycle is terminated. When power is restored or the AUTO mode is again selected, the display is reset to the preset value and another cycle begins. NOTE: A new timing cycle can be initiated ONLY after the sampling cycle has completed.

A. External Settings

1. THE DISPLAY:

The high intensity blue fluorescent display consists of three digits and decimal point (if decimal is set in tenths or hundredths position). Also, there is a blinking Timing Bar and a special Time-Out symbol. The Timing Bar appears to the right of the digits and blinks once every second during timing. The Timing Bar shows quickly that the timer is actively timing especially when the digits do not change rapidly as in the "hours" ranges. When the delay relay is energized at time-out, a triangular Time-Out symbol appears to the left of the digits. The Timing Bar blinks noticeably faster at time-out.

2. SETTING SWITCHES:

The three digits are set with the rotary switch knobs located beneath each digit. These knobs can be rotated in either direction (CW or CCW), and they are "pull" removable if digit set security is desired. Changing one or more digits, during timing, will instantly be reflected by an equivalent change in the timer's display. Setting all three digits to zero will cause instant time-out of the timer.

B. Internal Settings

THE 365 DIGITAL DISPLAY TIMER MUST BE REMOVED FROM ITS HOUSING TO ALTER ANY OF THE FOLLOWING SETTINGS.

1. TIME RANGE:

Decimal Point Location can be changed with the white plastic lever mounted behind the front face of the timer. This lever moves into three positions. With finger force you can change its position and at the same time observe the front of the timer. NOTE - this procedure sets the decimal point electronically as well as visually.

Time Units (Sec/Min/Hr) are set by moving a small width metal arm in a slotted arc on the side plate nearest to the units (Sec/Min/Hr) window. By depressing this arm slightly with a pencil or pen point, it can be moved to a new position. The time units physically change in the timer's face and the timer is electronically switched to the new units as well.

2. LINE FREQUENCY:

To set the proper line frequency, connect the jumper wire to either the 50 HZ or 60 HZ pin. These pins are clearly marked on the side of the timer.

NOTE: THE TIMER CHASSIS AND THE HOUSING ARE POLARIZED SO THAT THE CHASSIS CANNOT BE INSERTED INTO ITS HOUSING UPSIDE-DOWN. IF THE TIMER IS FORCED INTO THE HOUSING UPSIDE-DOWN DAMAGE WILL RESULT.

4.1.7 Digital Display Counter C-1 (Optional)

As arranged for use in this system, the counter operates in the DOWN & STOP mode. When the AUTO mode is selected, the illuminated display resets to the value dialed in to the Three Digit Preset. Immediately, the counter begins counting down. When the illuminated display reads all zeroes (000), the counter has "counted out" and initiates a sampling cycle. The sample probe extends and delays to collect a sample, then retracts at which time the limit switch LS-1 is actuated, then the auger motor is energized for an interval of time and the counter C-1 is reset (powered off), then the motor stops, and the counter display resets to the preset value and another counting interval is initiated. If the controller is shut off or the mode switched from AUTO to MANUAL, the counting cycle is terminated. When power is restored or the AUTO mode is again selected, the display is reset to the preset value and another cycle begins. NOTE: A new counting cycle can be initiated ONLY after the sampling cycle has completed.

A. External Settings

1. THE DISPLAY:

The high intensity blue fluorescent display consists of three digits and a Counting Bar with a special Count-Out symbol. The Counting Bar appears to the right of the digits and blinks once every count, regardless of range. When the delay relay is energized at count-out, a triangular Count-Out symbol appears to the left of the digits.

2. SETTING SWITCHES:

The three digits are set with the rotary switch knobs located beneath each digit. These knobs can be rotated in either direction (CW or CCW), and they are "pull" removable, if digit set security is desired. Changing one or more digits, during counting, will instantly be reflected by an equivalent change in the counter's display. Setting all three digits to zero will cause instant count-out of the counter.

B. Internal Settings

THE 366 DIGITAL DISPLAY COUNTER MUST BE REMOVED FROM ITS HOUSING TO ALTER THE COUNT RANGE:

The 366 has three ranges.

1x	=	Counts single pulses to 999
10x	=	Counts every tenth pulse to 9,990
100x	=	Counts every hundredth pulse to 99,900

Each range is selectable using finger force on the white plastic lever behind the front face of the counter. In two of the three possible lever positions, an indicator will appear in a range window located on the front face of the counter. When nothing appears in this window the count is in the x 1 range.

NOTE: THE COUNTER CHASSIS AND THE HOUSING ARE POLARIZED SO THAT THE CHASSIS CANNOT BE INSERTED INTO ITS HOUSING UPSIDE-DOWN. IF THE COUNTER IS FORCED INTO THE HOUSING UPSIDE-DOWN DAMAGE WILL RESULT.

4.1.8 Printed Circuit Board

The circuit board mounted inside the controller enclosure controls the solenoid valve and auger motor and serves as the connection point for all sampling system circuitry. Figure 4-2 illustrates a typical board. Depending upon

the options selected there may be minor differences. The following paragraphs describe the major components of the printed circuit board, their functions, and adjustments.

4.1.8.1 Main Fuse

This fuse, located along the top center of the board, protects the controller and sampler components against overloads and short circuits.

For 110/120 VAC, 1PH operation use ONLY a Buss Type FNM, 2 Amp, 250 Volt Slo-Blo fuse or equal.

For 220/240 VAC, 1PH operation use ONLY a Buss Type FNM, 1 Amp, 250 Volt Slo-Blo fuse or equal.

4.1.8.2 Motor Fuse

This fuse, located at the top left corner of the board, protects the motor against overloads and short circuits.

For 110/120 VAC, 1PH operation use ONLY a Buss Type FNM, 12 Amp, 250 Volt Slo-Blo fuse or equal.

For 220/240 VAC, 1PH operation use ONLY a Buss Type FNM, 6 Amp, 250 Volt Slo-Blo fuse or equal.

4.1.8.3 PC Board Fuse F3

This fuse, located to the right on the middle of the board, protects the printed circuit board against overloads and short circuits. Use ONLY a Buss Type AGC, 1-1/2 Amp, 250 Volt fast acting fuse or equal.

4.1.8.4 Motor Timer Switches (Tens & Ones)

These rotary switches can be adjusted to vary the length of time the motor is energized and rotating the auger during each sampling cycle to discharge a collected sample.

NOTE: MOTOR RUN TIME IS TO BE ADJUSTED TO ALLOW THE AUGER TO CLEAN OUT THE SAMPLE TUBE AT THE END OF EACH CYCLE. MINIMUM RUN TIME WILL DEPEND ON THE CHARACTERISTICS OF THE MATERIAL BEING SAMPLED AND MAY WELL REQUIRE RE-ADJUSTMENT IF THE PRODUCT BEING SAMPLED CHANGES.

Utilizing a small screw driver turn the slotted rotor of the tens and/or ones switches to desired length of time the motor is energized during a cycle. The time period can be adjusted from 1 to 99 seconds. The timer is factory set at 15 seconds.

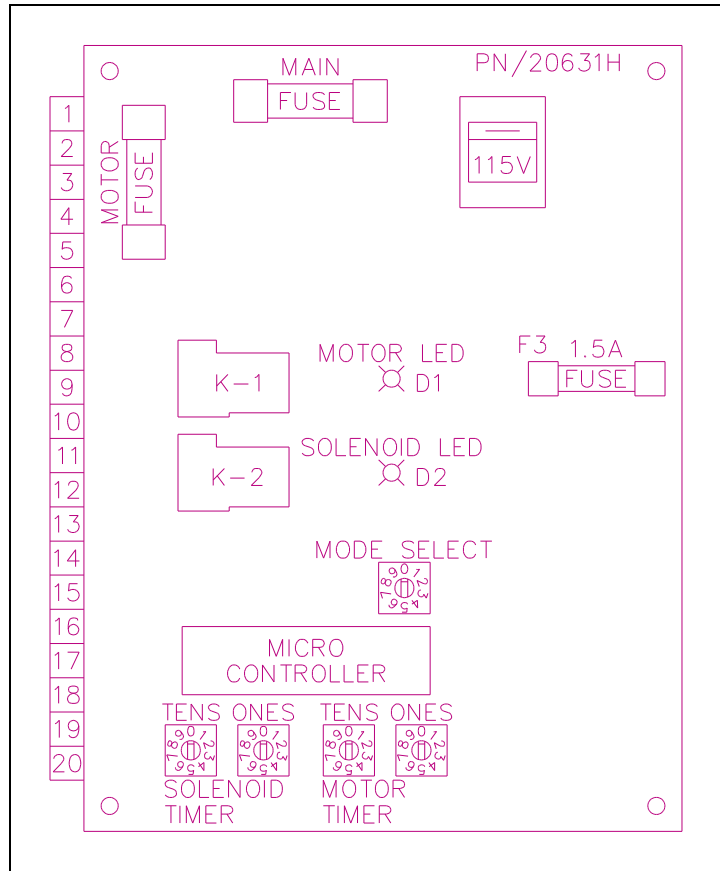

FIGURE 4-2, PRINTED CIRCUIT BOARD

The ones switch is in increments of one second and the tens switch is in increments of ten seconds. As an example, to set the motor timer to 20 seconds, turn the tens rotor to setting 2 and turn the ones setting to 0. The solenoid timer setting would be set in the same manner.

4.1.8.5 Solenoid Timer Switches (Tens & Ones)

These rotary switches can be adjusted to vary the length of time the sample tube solenoid valve is energized to extend the sample tube into the product stream during each sample collection cycle.

NOTE: SOLENOID VALVE TIME IS TO BE ADJUSTED SO THAT THE SAMPLE TUBE EXTENDS INTO THE PRODUCT STREAM ONLY LONG ENOUGH TO ALLOW A REPRESENTATIVE SAMPLE TO BE COLLECTED. EXTENDING THE SAMPLE TUBE INTO THE PRODUCT STREAM FOR EXCESSIVELY LONG PERIODS OF TIME CAN RESULT IN UNNECESSARY SAMPLE TUBE WEAR AND CAN RESULT IN CLOGGING OF PRODUCT FLOWING THROUGH THE CONVEYING LINE.

Utilizing a small screw driver turn the slotted rotor of the tens and/or ones switches to desired length of time the sample tube solenoid valve is energized during a cycle. The time period can be adjusted from 1 to 99 seconds. The timer is factory set at 4 seconds. Refer to Section 4.1.8.4 for further explanation on time settings.

4.1.8.6 Motor LED Indicator

This LED (D1) is illuminated when power is present to K-1 relay coil on the PC board. It is a visual signal showing when the motor should be running.

4.1.8.7 Solenoid LED Indicator

This LED (D2) is illuminated when power is present to K-2 relay coil on the PC board. It is a visual signal showing when the solenoid valve should be energized.

4.1.8.8 Mode Select Switch

The switch, located at the lower center of the circuit board, determines the sequencing of certain internal controller events.

As this board is used in controllers for several different samplers, MODE switch settings allow the board's functions to be tailored to the requirements of the various samplers.

NOTE: HD-PP SAMPLERS REQUIRE THE MODE SWITCH TO BE POSITIONED ON SETTING "0" (ZERO). IF THE MODE SETTING IS NOT CORRECTLY SET, TURN POWER OFF TO THE CONTROL PRIOR TO RE-SELECTING. THE PC BOARD WILL ONLY CHANGE MODES WHEN POWER IS INITIALLY APPLIED.

4.1.8.9 Terminal Strip

This 20-position barrier terminal strip is located along the left edge of the circuit board. It serves as the controller's interface and connection point for all external circuits and for the components mounted on the enclosure's front panel. Refer to the certified electrical drawing(s).

4.1.8.10 115V/230V Switch

This switch is factory set to allow a common PC board to be operated on either 115 vac, 50/60 hz or 230 vac, 50/60 hz. The printed circuit board operating voltage can only be switched after all electrical components connected to it are changed. To field convert the control and sampler operating voltage, determine what components will need to be replaced. Typically this includes, but is not limited to: the digital display timer, power lamp & socket, fuse(s), solenoid coil(s), and possibly the motor. Refer to the name plate and wiring diagram on the motor to determine if the motor is rated for the desired voltage. If it is, change the wiring connections in the motor junction box for operation on the new voltage.



4.2 Sampler Mounted Electrical Components

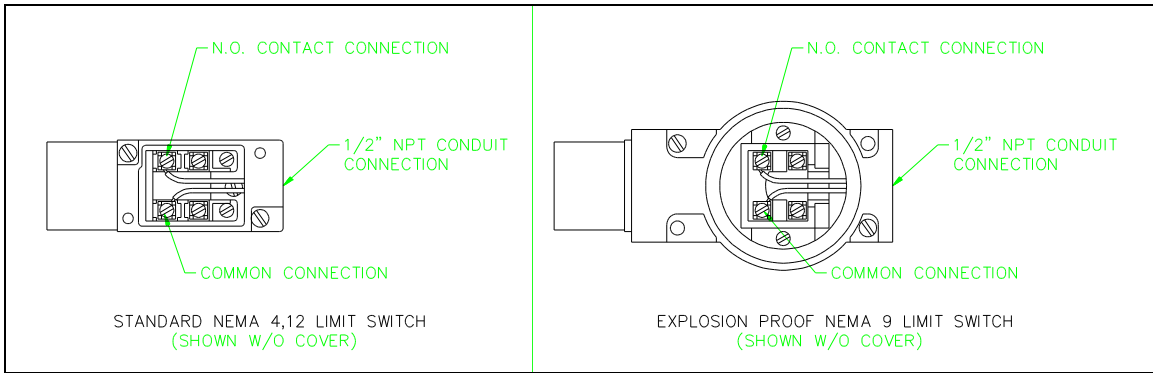

FIGURE 4-3, LIMIT SWITCH CONNECTIONS

4.2.1 Limit Switch, LS-1

This switch is actuated when the sample probe is in its retracted position. Upon retraction of the sample probe the limit switch is actuated and the closure of the normally open contacts signals the controller to allow the auger motor to run.

Correct wiring termination is essential to proper sampler operation. Refer to figure 4-3, it shows two models utilized on the HD-PP sampler and the physical orientation of the proper wiring connections.

4.2.2 Auger Drive Motor

This motor is direct coupled to the gear reducer and drives the sample auger through a set of right angle bevel gears. A label is located on the motor designating the correct direction of rotation (reference Figure 1-1). Verify that the motor is turning the proper direction of rotation when wiring the system. On initial setup, test run the sampler when no material to be sampled is present (conveying line shut down, hopper empty, etc.). This will prevent the sample auger from jamming if the motor is running backwards.

NOTE: DO NOT RUN THE MOTOR THE WRONG DIRECTION. EXTENSIVE DAMAGE TO THE SAMPLER WILL RESULT.

FIGURE 4-4, SOLENOID VALVE

4.3 Pneumatic Components

4.3.1 Solenoid Valve V-1

This valve is a 4-way, 2 position, spring return, single solenoid operated control valve. This valve controls the air cylinder, alternately pressurizing the cap end and rod end of the cylinder to extend and retract the sample tube.

When the valve's solenoid is energized, the internal valve spool shifts, pressurizing the cap end of the cylinder. The cylinder extends, pushing the sample probe into the product stream. When the solenoid is de-energized, the spring operator forces the valve spool to shift again, pressurizing the rod end of the cylinder. The cylinder retracts, pulling the sample probe from the product stream.

The valve has a manual over-ride button that allows the operator to cycle the sampler air cylinder without the aid of the controller. By pushing the manual over-ride button, the internal valve spool is positioned manually and the sampler air cylinder will extend and remain there until the button is released. When the over-ride button is released the cylinder will return to its home position.

4.3.2 Needle Valve (Optional)

This valve regulates the air flow feeding the purge option. This valve will require some adjustment upon initial sampler start up. Figure 4-5 shows the two available purge configurations.

A. The "Sample Purge" type aids in the flow of material out of the sampler and into the sample container. This purge, which is controlled by the sample purge solenoid valve V-2, forces air into the sample probe.

B. The "Lantern Ring Purge" helps keep the material being sampled away from the sampler packing seals. This purge, which only has the needle valve for control, forces air continuously ahead of the probe seals to keep the sampled material from being forced into the seals.

4.3.3 Purge Solenoid Valve V-2 (Optional)

This valve operates the sample purge option. The valve is a 2-way, normally closed, spring return, single solenoid operated control valve. As shown in Figure 4-5, it is plumbed in conjunction with the needle valve to correctly control the purge air flow. The purge solenoid is typically wired in parallel with sampler auger motor. So that when the sample auger is turning the purge air is being fed into the sample probe thus aiding in the flow of material out of the sampler. Refer to the certified electrical drawing(s) for proper wiring requirements.

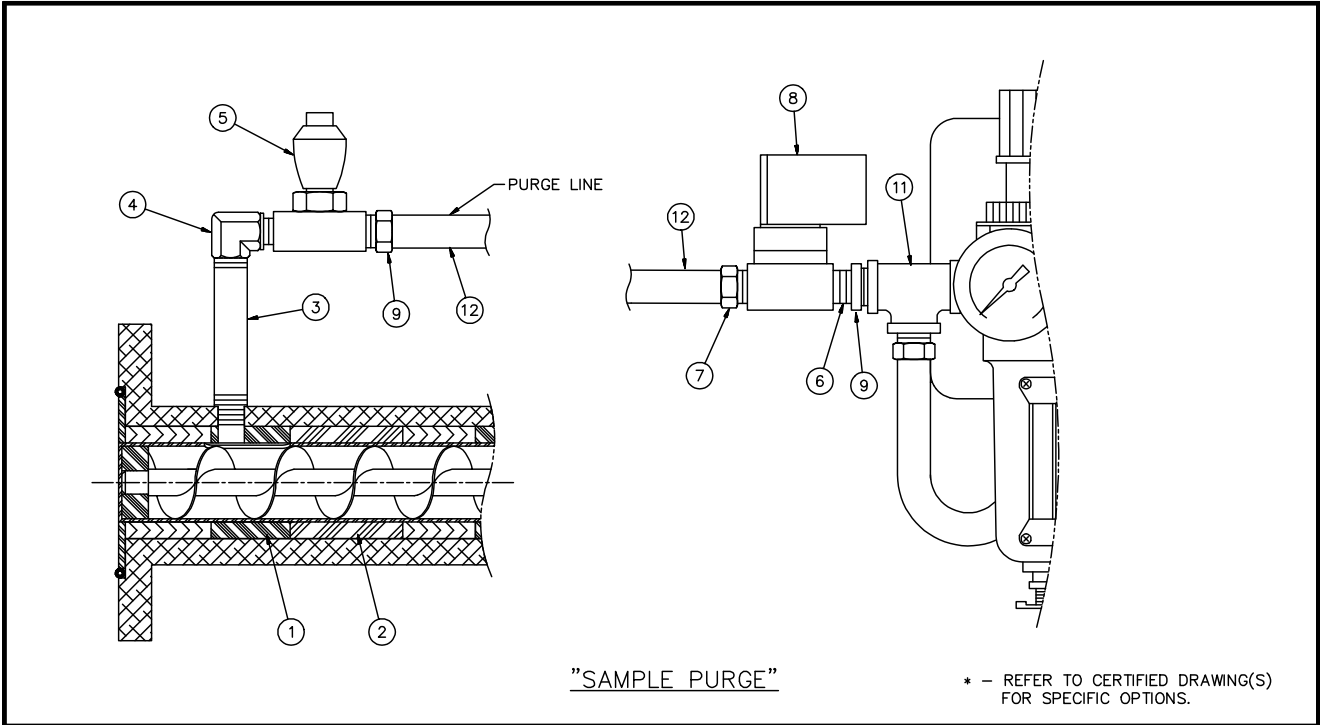

"LANTERN RING PURGE"

ONE VEE RING IS REMOVED TO ACCOMMODATE LANTERN RING.

12	4 FT	3/8 I.D. AIR HOSE	24550	-
11	1	BRASS PIPE TEE 1/2 NPT	24565	-
10	1	LANTERN RING 3 x 3-3/4 x 5/16	-	-
9	1	BRASS PIPE BUSHING 1/2 TO 3/8	34435	-
*	8	1 2-WAY XP SOLENOID VALVE 3/8	515877	-
	8	1 2-WAY SOLENOID VALVE 3/8 NPT	515679	-
	7	2 3/8 PUSH-LOC TO 3/8 MPT STR	24553	-
	6	1 BRASS PIPE CLOSE NIPPLE 3/8	512823	-
	5	1 3/8 NEEDLE VALVE	28194	-
	4	1 BRASS 90° STREET ELBOW 3/8	34451	-
	3	1 BRASS PIPE NIPPLE 3/8 x 2-1/2 LG	34448	-
*	2	1 HD-PP EXTRA SEAL SPACER 316SS	524999	-
	2	1 HD-PP EXTRA SEAL SPACER NYLON	518997	-
		HD-PP-10 & 12 SAMPLERS ONLY		
*	1	1 HD-PP-12 FRONT SEAL SPACER 316SS	514998	-
	1	1 HD-PP-12 FRONT SEAL SPACER NYLON	514079	-
*	1	1 HD-PP-10 FRONT SEAL SPACER 316SS	524997	-
	1	1 HD-PP-10 FRONT SEAL SPACER NYLON	513245	-
*	1	1 HD-PP-8 FRONT SEAL SPACER 316SS	524998	-
	1	1 HD-PP-8 FRONT SEAL SPACER NYLON	514079	-
*	1	1 HD-PP-6 FRONT SEAL SPACER 316SS	524997	-
	1	1 HD-PP-6 FRONT SEAL SPACER NYLON	513243	-
ITEM NO.	QTY	SIZE AND MATERIAL	PRODUCT CODE	TOTAL UNITS
BILL OF MATERIALS			PRODUCT STRUCTURE	

FIGURE 4-5, OPTIONAL PURGE CONFIGURATIONS

4.3.4 Air Filter/Pressure Regulator

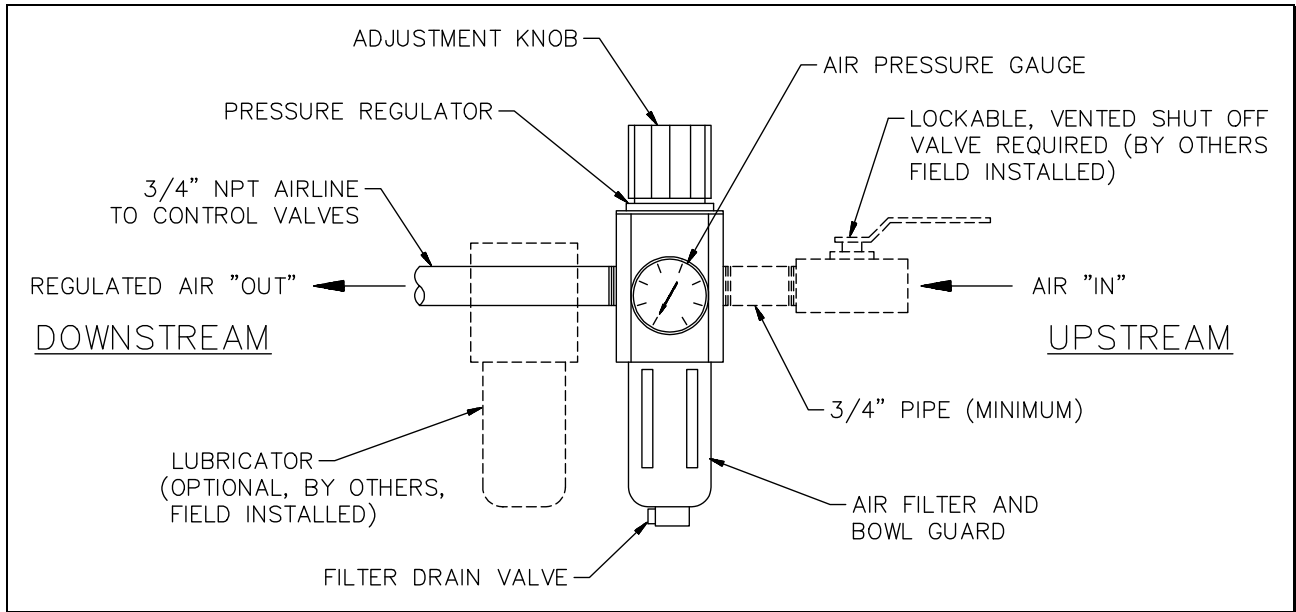

FIGURE 4-6, FILTER/REGULATOR

The air filter/regulator assembly provides a clean and regulated air supply to the samplers pneumatic components. A pressure gauge gives the operator an accurate reading of the downstream air pressure. The regulator is equipped with an adjustment knob for controlling the outlet pressure and a manual "pet-cock" type drain for draining the filter bowl.

Prior to introduction of air supply, turn the adjustment knob counter-clockwise until all load is removed from the regulating spring. Turn on system air pressure. Turn adjustment knob clockwise until desired outlet pressure is reached.

To avoid minor re-adjustments after making a change in the pressure setting, always approach the desired setting from a lower pressure. When reducing from a higher setting to a lower setting, first reduce to a pressure setting lower than desired and then adjust upward.

To "lock-in" the pressure setting on the regulator, push the lockring on the adjustment knob down until it snaps into place. To release pull the lockring upward. The pressure setting can be made tamper resistant by installing a seal wire in the groove above the lockring.

4.3.5 Pneumatic Cylinder

This double-acting air cylinder extends and retracts the sample probe. Stroke length varies with the sample probe stroke. The cylinder rod is connected to the sample probe by means of the threaded probe adjustment rods. Solenoid valve V-1 controls extension and retraction of the cylinder.

V. MAINTENANCE AND REPAIR

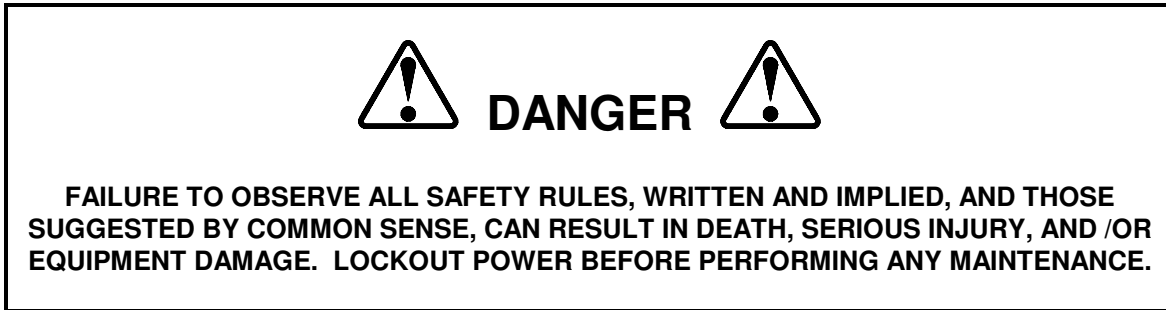

5.1 General Maintenance

A good maintenance program involves thorough general housekeeping, adequate periodic re-lubrication, and replacement of worn or damaged components.

5.2 Periodic Inspection

At regularly scheduled intervals, while observing all safety precautions, observe the sampler as it operates. Inspect for:

- A. Loose or missing hardware
- B. Noisy motor or motor/reducer bearings
- C. Overheated motor or reducer
- D. Adequate lubricant in lubricator and gear reducer
- E. Structural damage
- F. Rust or corrosion
- G. Damaged wiring, including exposed conductors and connections
- H. Damaged airlines or pneumatic components
- I. Make sure that all guards are in place and that all warning labels are in place and legible. Section I, GENERAL SAFETY INFORMATION, explains the purpose and intended location of the warning signs. Warning signs are an important part of any safety program; replace any missing signs IMMEDIATELY!

5.3 Lubrication

5.3.1 Auger Bevel Gears

The auger bevel gears are designed to run dry. If grease is applied to the gears, extra care must be taken to ensure that the grease remains free from contaminants.

5.3.2 Airline Lubricator

An airline lubricator is not required. The cylinder is of a non-lube design requiring NO lubrication. If the use of a lubricator is desired, it must be field mounted between the F/R and the directional control valve. If a lubricator has been added to the system, the user must determine the appropriate lubricant and the proper intervals for refilling the reservoir. Refer to the manufacturer's technical literature. Note that by introducing oil into the airline, it will be discharged into the surrounding environment near the air exhausts of the directional control valve(s) on the sampler.

5.4 Draining and Servicing the Filter

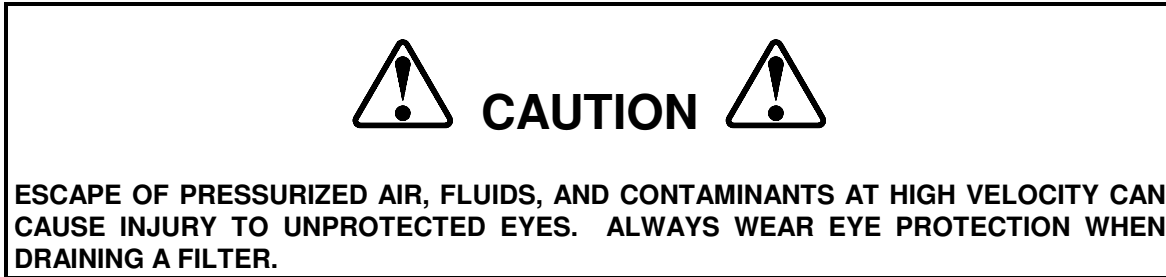

Drain the accumulated fluid whenever the fluid level in the reservoir (quiet-zone) rises to the lower baffle. Filters have either a screw-type drain or a push-type drain. If the filter requires frequent draining, consider installing an automatic drain or an air drying system. Periodically, the bowl may need to be removed to clean out accumulated moisture and contaminants.

- A. Shut off and lock out the air supply.
- B. Operate a valve or loosen an airline connection to relieve all pressure downstream from the filter/regulator.
- C. Remove and clean the bowl; various types of clamp rings or threaded collars are used to retain bowls.

NOTE: THE BOWLS OF FILTER/REGULATORS CAN NOT BE REMOVED WHILE PRESSURIZED! INTERNAL PRESSURE PREVENTS THE CLAMP RING OR THREADED COLLAR FROM TURNING.

- D. Clean or replace the filter element.
- E. If the bowl seal is damaged or brittle replace it. In any event lightly coat the seal with petroleum-based grease to help hold it in position.
- F. Reinstall the bowl. Turn on pressure and make sure the bowl is seated and sealed.

5.5 Mechanical Repair Procedures

5.5.1 Adjustment of Seal Pressure

A series of v-ring packing assemblies and spacers within the seal housing support and seal the sample tube. When the sampler has operated for an extended period of time, the seals may wear or extrude. If evidence of leaking from the conveying line along the sample tube is noticed, first try to increase the compressive force on the seal and spacer stack.

As shown on the section drawings of the samplers in Section VII, the v-ring packing seals are held compressed by the compression plate. Two 3/8-16UNC hex head screws clamp the plate to the rear flange of the seal housing. Using 9/16" wrenches evenly tighten the two cap screws a 1/2 turn at a time. This will compress the seal and spacer stack, increasing the seal effect on the sample tube.

NOTE: EXCESSIVE COMPRESSION ON THE SEAL AND SPACER STACK WILL RESULT IN PERMANENTLY DEFORMED & INEFFECTIVE SEALS THAT WILL HAVE TO BE REPLACED. IT IS POSSIBLE TO OVER TIGHTEN THE SEAL AND SPACER STACK WHICH CAN RESULT IN THE SEIZURE OF THE SAMPLE TUBE, RENDERING IT INCAPABLE OF EXTENDING OR RETRACTING.

If the leak can not be stopped by adjusting seal pressure, then the seals will have to be replaced as explained in Section 5.5.2.

5.5.2 Seal Replacement

When following the instructions below, refer to the applicable drawing of the sampler. Reference the drawings in Section VII and the certified drawing(s).

- A. Shutoff and lockout all power (electrical and pneumatic).
- B. Shut down conveying line and remove the sampler assembly. Install a properly designed cover plate over the hole in the conveying line. Save the gasket(s); if any have deteriorated or are damaged, order replacements.
- C. In order to remove the seals, remove and retain the following components and save ALL fasteners:
 1. Remove the top and bottom covers of the sampler.
 2. Remove the four 5/16-18UNC hex head bolts attaching the side panels to the seal housing and the four 1/2-13UNC hex head bolts attaching the guide rods to the seal housing.
 3. Remove the two 3/8-16UNC hex head compression plate screws and nuts.
 4. Pull the seal housing off of the sample probe.
 5. Remove the 1/4-20UNC hex head screws(s) over the discharge spacer and the front spacer.
 6. Remove the four 1/4-20UNC flat head screws attaching the seal retainer to the seal housing.
 7. Remove the seals and spacers taking care to avoid damaging the seal housing bore. Use a 3.5" dia. round plastic bar or wooden dowel to push with, if necessary.
 8. Replace worn items and clean the remaining components. And remove any burrs or scratches from the bore of the seal housing.
- D. Rebuild the sampler in the following order.
 1. Re-install the seal retainer plate using the four 1/4-20UNC flat head screws.
 2. Refer to the Teflon Seal Spacer Arrangement, Figure 7-1, it illustrates the order of insertion and orientation of seals and spacers. Carefully insert the seals and spacers from the rear of the seal housing, pushing them towards the front.
 3. Re-install the 1/4-20UNC hex head screw(s) over the discharge spacer and the front spacer.

4. Position the compression plate so that it bears on the end of the rear spacer. Loosely re-install the two 3/8-16UNC hex head screws and nuts which clamp the plate to the seal housing flange.
 5. Carefully slide the seal housing over the sample tube and into position.
 6. Re-install the four 5/16-18UNC hex head bolts fastening the side plates to the seal housing. And the four 1/2-13UNC hex head bolts fastening the guide rod to the seal housing. Make certain that the seal housing is aligned with the sample tube so there is no side thrust. Then securely tighten all the screws.
 7. Evenly tighten the compression plate screws to firmly compress the seal and spacer stack.
- E. Remove the cover plate on the sample conveying line and reattach the sampler.
- F. Restore power to the sampler and operate it through several collection cycles. If leaks along the sample tube are detected, tighten both compression plate screws 1/2 turn. Make sure compression plate flange remains parallel to the seal housing flange. Repeat the process until no leakage is detected.
- G. Re-install the top and bottom covers of the sampler.

5.5.3 Sample Probe, Auger And Seal Replacement

When following the instructions below refer to the applicable drawing of the sampler. Reference the drawings in Section VII and the certified drawing(s).

- A. Follow instructions in Section 5.5.2 "A" through "C".
- B. Disconnect the sample probe from the air cylinder assembly by removing the two 3/4" hex head nuts on the threaded adjustment rods
- C. Remove the two 1/4-20UNC hex head lock nuts and bolts that fasten auger bearing housing to the sample probe. Pull the sample probe off the auger and the auger bearing housing.
- D. Loosen the two set screws on the 28 tooth bevel gear and remove from the auger shaft.
- E. Use a fine file or emery paper to remove any screw burrs from the end of the auger shaft.
- F. Remove the auger from the bearing housing. Be sure to save the thrust washers on the auger shaft.
- G. Clean and inspect any items to be reused. Replace if worn or damaged.
- H. Re-assemble the auger, thrust washer, auger bearing housing, thrust washer and 28 tooth bevel gear. Keeping the assembly tight. Align one of the set screws directly over the flat spot on the auger shaft and tighten both set screws.
- I. Carefully slide the auger and bearing housing assembly back into the sample probe. Make sure that the front shaft of the auger slips into the auger end bearing located inside the capped end of the sample probe.
- J. Align the holes in the sample probe and the auger bearing housing. Re-install and tighten the 1/4-20UNC hex head bolts with lock nuts.
- K. Re-assemble the sample probe to the air cylinder assembly by replacing the two 1/2-13UNC hex head nuts on the threaded adjustment rods. Make sure the air cylinder is fully retracted and check for proper meshing of the gears; there must be full depth engagement of the gear teeth, but no bending of the gearmotor shaft.

NOTE: IF THE GEAR TEETH DO NOT MESH PROPERLY, THE GEARS WILL WEAR RAPIDLY.

L. Continue by following instructions in Section 5.5.2 "D" through "G"

5.5.4 Bevel Gears Replacement

When following the instructions below refer to the applicable drawing of the sampler. Reference the drawings in Section VII and the certified drawing(s).

NOTE: ALWAYS REPLACE BEVEL GEARS IN SETS. REPLACING A SINGLE GEAR IS A FALSE ECONOMY AS THE NEW GEAR WILL WEAR IMMEDIATELY.

- A. Shutoff and lockout all power (electrical and pneumatic).
- B. Shut down conveying line and remove the sampler assembly. Install a properly designed cover plate over the hole in the conveying line. Save the gasket(s); if any have deteriorated or are damaged, order replacements.
- C. Remove the top and bottom covers of the sampler.
- D. Remove the four 5/16-18UNC hex head bolts attaching the motor side panel to the seal housing and cylinder mount plate.
- E. Loosen the two set screws in the 28 tooth bevel gear and slip it off the gearmotor shaft. Leave the gear spacer on the shaft unless it requires replacement. Save the shaft key.
- F. Install the new 28 tooth bevel gear on the gearmotor shaft (it should be tight against the spacer). Make sure the shaft key is in place and tighten the set screws.
- G. Disconnect the sample probe from the air cylinder assembly by removing the two 1/2-13UNC hex head nuts on the threaded adjustment rods
- H. Extend the sample probe into the seal housing by pushing on the end of the probe.
- I. Loosen the two set screws in the 28 tooth bevel gear and slip it off the auger shaft. Leave the thrust washer on the shaft unless it requires replacement.
- J. Install the new 28 tooth bevel gear on the auger shaft (make sure the thrust washer is in place). Insert a wooden stick or soft metal bar into the sample slot opening and push the auger tight against the auger bearing housing. Keeping the assembly tight. Align one of the set screws directly over the flat spot on the auger shaft and tighten both set screws.
- K. Replace the motor side panel assembly. Re-install the four 5-16-18UNC hex head bolts and tighten.
- L. Retract the sample probe into the seal housing by pushing on the end of the probe. And reconnect the sample probe to the air cylinder assembly by replacing the two 1/2-13UNC hex head nuts on the threaded adjustment rods. Make sure the air cylinder is fully retracted and check for proper meshing of the gears; there must be full depth engagement of the gear teeth, but no bending of the gearmotor shaft.

NOTE: IF THE GEAR TEETH DO NOT MESH PROPERLY, THE GEARS WILL WEAR RAPIDLY.

M. Remove the cover plate on the sample conveying line and reattach the sampler.

N. Restore power to the sampler and operate it through several collection cycles. If leaks along the sample tube are detected, tighten both compression plate screws 1/2 turn (making sure compression plate flange remains parallel to the seal housing flange). Repeat the process until no leakage is detected.

O. Re-install the top and bottom covers of the sampler.

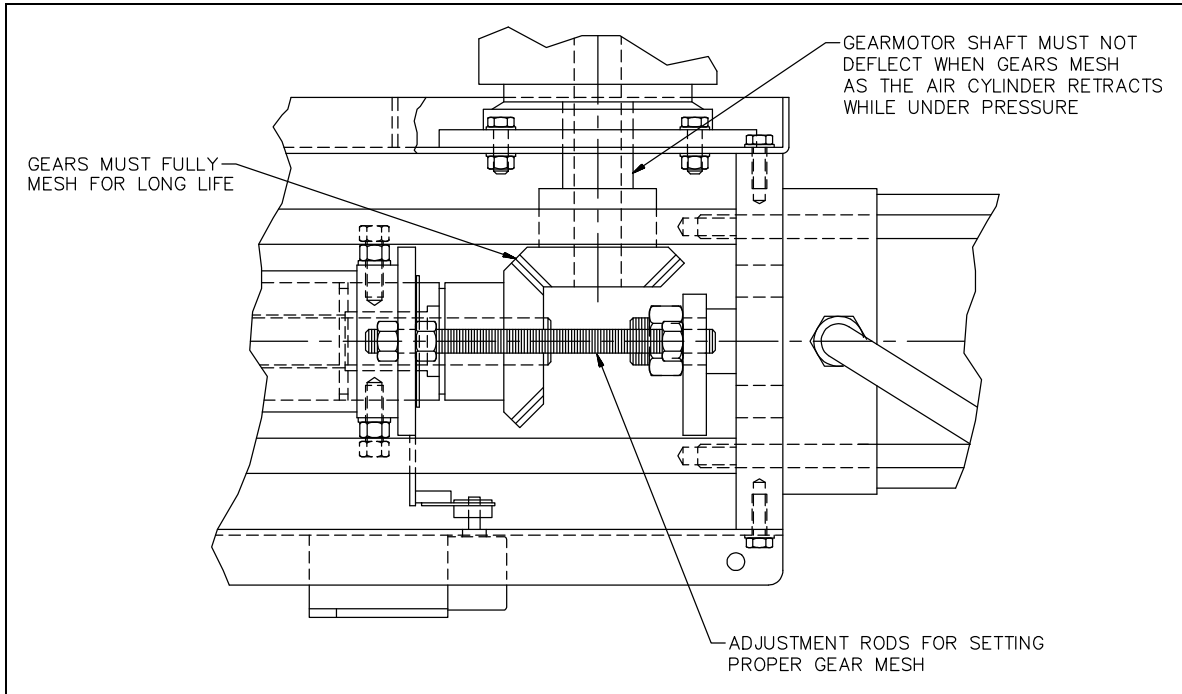
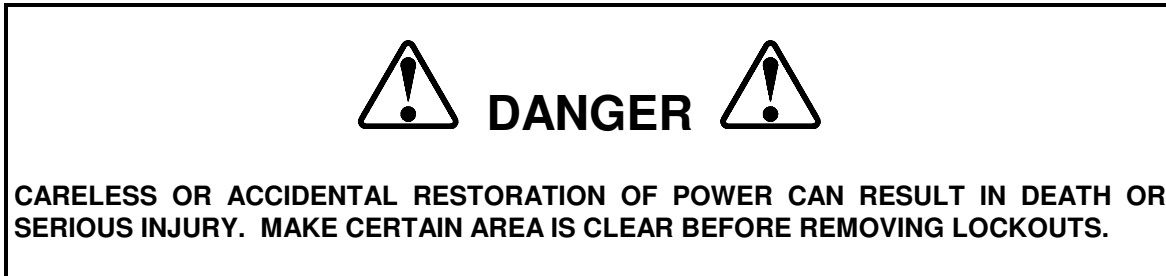

FIGURE 5-1, BEVEL GEAR ALIGNMENT

VI. TROUBLESHOOTING

6.1 General HD-PP Sampler Troubleshooting



SYMPTOM	POSSIBLE CAUSE	CORRECTIVE ACTION
Sampler does not cycle in either auto or manual modes (Power light Off).	Power switch OFF.	Turn power switch ON.
	Circuit breaker is open.	Reset breaker.
	Main fuse is blown.	Replace. Refer to Section 4.1.8.1.
	Faulty supply wiring.	Correct. Refer to certified electrical schematic.
	Defective power switch.	Replace switch.
Sampler does not cycle in either auto or manual modes (Power light On).	Faulty system wiring.	Correct. Refer to certified electrical schematic.
	No or low air pressure.	Turn air supply on and set regulator to 80-100 PSI.
	PC board fuse is blown.	Replace. Refer to Section 4.1.8.3.
	Defective control valve.	Refer to Section 6.3.
Sampler timer T-1 digital display does not illuminate but sampler works in manual mode.	Defective auto/manual switch S-2.	Replace switch if line voltage is absent across #1 & #2 on timer T-1.
	Defective timer T-1.	Replace timer if line voltage is present across #1 & #2 on timer T-1.
Sample size too small or large.	Solenoid time on setting too low or high.	Adjust solenoid time setting on PC board refer to Section 4.1.8.5.
Sampler sluggish (Operates too slowly).	Inadequate air supply.	Increase line size or add surge tank.
	Regulator set too low.	Reset. Refer to Section 4.3.4.
	Filter clogged.	Clean as outlined in Section 5.4.
	Airline from filter regulator blocked or damaged.	Inspect and correct.
	Cylinder seal leakage.	Refer to Section 6.4.

General HD-PP Sampler Troubleshooting (continued)

SYMPTOM	POSSIBLE CAUSE	CORRECTIVE ACTION
Auger bevel gears wear rapidly.	Gears are not meshing properly.	Adjust. Refer to Section 5.5.4.
	Sample container over filling and material is backing up into the sampler.	Empty sample container promptly or incorporate a sensor to shut off the sampler when the container is full.
	Limit switch LS-1 not wired properly or defective.	Inspect. Refer to Section 4.2.1.
	Large air pressure drop during sampling cycle.	Increase air supply line size. Refer to Section 3.8 & 3.8.1.
Sampler makes loud banging noise when probe retracts.	Gears are rotating after disengagement.	Make sure motor is coming to a complete stop before taking another sample.
Sampler leaks air or material continuously out the sample discharge.	Packing seals not tight.	Tighten. Refer to section 5.5.1.
	Packing seals worn out.	Inspect & replace. Refer to Section 5.5.2.
	Sample probe worn out.	Inspect & replace. Refer to Section 5.5.3.
Auger motor runs when probes extends.	Mode select switch on printed circuit board improperly set.	Inspect. Refer to Section 4.1.8.8.
	Limit switch LS-1 not wired properly or defective.	Inspect. Refer to Section 4.2.1.
Auger motor does not run (Probe extends and retracts).	Motor not wired properly.	Correct. Refer to certified electrical schematic.
	Defective motor.	Replace.
	Motor fuse blown.	Replace. Refer to Section 4.1.8.2.
	Defective PC board.	Replace. Refer to Section 6.2.
Sample probe does not extend or retract.	No or low air pressure.	Turn air supply on and set regulator to 80-100 PSI.
	Defective control valve.	Refer to Section 6.3.
	Material caked up in seals.	Inspect & replace. Refer to Section 5.5.2.
	Defective air cylinder seals.	Inspect & replace. Refer to Section 6.4.1.
	Sample probe bent or jammed.	Inspect & replace. Refer to Section 5.5.3.

6.2 PC Board Troubleshooting

SYMPTOM	POSSIBLE CAUSE	CORRECTIVE ACTION
Motor fuse blows continuously.	Motor wired improperly.	Correct. Refer to the certified electrical schematic.
	Motor jammed.	Inspect & replace.
	Auger seized up in sampler.	Inspect & replace. Refer to Section 5.5.3.
	Timer T-1 defective.	Inspect & replace. Refer to Section 4.1.6.
Sampler probe extends and retracts but motor does not run. (control resets).	Low voltage power supply.	107 vac minimum for 110/120 vac. 215 vac minimum for 220/240 vac.
	Inadequate power supply wiring.	Monitor voltage when motor starts. It should not drop below 107 vac, or 215 vac.
Sampler digital display timer T-1 does not illuminate when in auto mode.	Motor fuse blown.	Replace. Refer to Section 4.1.8.2.
	Defective PC board.	Replace.
Motor and/or solenoid times cannot be adjusted.	Defective PC board.	Replace.
Solenoid LED illuminates but no full line voltage signal at terminal #13.	Defective PC board.	Replace.
	Improper ground wiring.	Correct. See note below.
Motor LED illuminates but no full line voltage signal at terminal #10.	Motor fuse blown.	Replace. Refer to Section 4.1.8.2.
	Defective PC board.	Replace.
	Improper ground wiring.	Correct. See note below.

NOTE: HD-PP SAMPLERS REQUIRE THE MODE SWITCH TO BE POSITIONED ON SETTING "0" (ZERO). IF THE MODE SETTING IS NOT CORRECTLY SET, TURN POWER OFF TO THE CONTROL PRIOR TO RE-SELECTING. THE PC BOARD WILL ONLY CHANGE MODES WHEN POWER IS INITIALLY APPLIED.

NOTE: SAMPLER MAY FAIL TO OPERATE OR OPERATE IMPROPERLY IF THE DC GROUND TRACE ON THE PC BOARD IS NOT ISOLATED FROM THE AC GROUND OR NEUTRAL WIRING. REFER TO THE CERTIFIED ELECTRICAL DRAWING(S) FOR AC GROUND CONNECTIONS.

6.3 Directional Solenoid Valve Troubleshooting

SYMPTOM	POSSIBLE CAUSE	CORRECTIVE ACTION
Valve does not shift but full line voltage signal is present across #5 & #13 on PC board.	No or low air pressure.	Turn on air supply and set regulator to 80-100 PSI.
	Faulty field wiring.	Check for full line voltage at the solenoid.
	Solenoid coil burnt out.	Replace coil if no continuity through coil.
	Valve clogged or stuck.	Remove & clean. Or replace.
Valve leaks air continuously out an exhaust port.	Defective valve seals.	Refer to Section 6.4.2.
	Defective cylinder seals.	Refer to Section 6.4.2.

There must be at least 60 PSI pressure at the valve. The valve pilot operators are air assisted. If there is insufficient pressure the valve will not shift or may not shift completely.

Observe the pressure gauge. Assume the gauge indicates sufficient pressure when the sampler is idle, 85 PSI for example. If the pressure drops significantly to perhaps 55 PSI when the valve shifts, a blocked or damaged air line should be suspected.

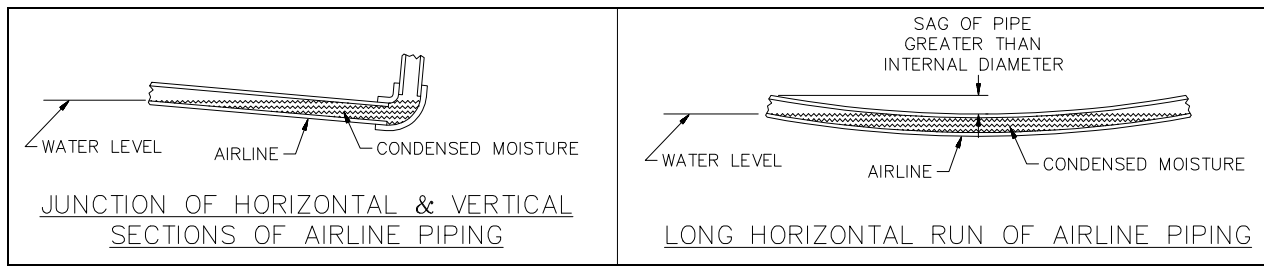

FIGURE 6-1, CONDENSED MOISTURE BLOCKING AIRLINE

One often overlooked cause of insufficient air flow is moisture condensing and collecting in a low spot in the supply line. Figure 6-1 illustrates an exaggerated example of such a problem. It can be seen that if the pipe sags only slightly over a long distance and water collects in the low spot over an extended period of time, the airline could be partially or completely blocked. A similar condition often occurs where there is a junction of horizontal and vertical sections of an air line.

This problem is particularly prevalent when there is high ambient humidity and the equipment operates infrequently and intermittently, as in the case of a sampler.

NOTE: ALL HORIZONTAL RUNS OF AN AIRLINE SHOULD HAVE A MOISTURE TRAP AND THE TRAPS SHOULD BE DRAINED FREQUENTLY; AT LEAST ONCE A DAY; ESPECIALLY, WHEN HUMIDITY LEVELS ARE HIGH.

6.4 Air Components Troubleshooting

6.4.1 Cylinder Leaking

A. External Leakage

1. Rod seal leakage can generally be traced to worn or damaged seals. Examine the piston rod for wear or damage. Replace the rod and seals if rod's surface is rough or worn out-of-round.
2. Soft or gummy seals are evidence of incompatibility with some substance in the air supply. Evaluate the area where the air intake is located. If an airline lubricator is included in the system, check to see if the lubricant being used is compatible with the seal material.

B. Internal Leakage

1. The lipseal piston seals are virtually leak free unless they are worn or damaged. Replace defective seals.
2. Contaminants in the air supply can lead to scored cylinder walls, resulting in rapid seal wear. If such is the case, check to see if the filter is being drained frequently. A different type of filter may be required; one that can remove finer particles or one that can filter out different kinds of contaminants.
3. Possible piston cylinder leakage, apparently indicated by piston drift is not always traceable to the piston. A leak through a closed valve port can also cause piston drift.

To determine if a piston is leaking, use a manual override to pressurize one end of the cylinder in question. When the cylinder has completed its stroke but is still pressurized, carefully remove the airline from the other cylinder port that presumably is not pressurized. If air can be detected leaking from the airline connected to the supposedly unpressurized port, then the problem lies elsewhere in the pneumatic system.

6.4.2 Valve vs. Cylinder Leak Test

When there is continuous leakage out of a valve exhaust port, proceed as follows to determine if the leak is caused by defective valve seals or by defective cylinder seals.

A. Cylinder retracted as shown in Figure 6-2A

1. If there is continuous leakage out of Port "5", the valve seals are defective and must be replaced.
2. If there is continuous leakage out of Port "3", the problem can be with the valve seals or the cylinder seals. To determine which proceed as follows:
 - a. Disconnect the line between Valve Cylinder Port "2" and the cylinder per Figure 6-2B.
 - b. If leakage continues out of Port "3" and/or Cylinder Port "2", the valve seals are defective and must be replaced.
 - c. If there is a leakage out of the line from the cylinder, the cylinder seals are defective and must be replaced.

B. Cylinder extended as shown in Figure 6-2C.

1. If there is continuous leakage out of Port "3", the valve seals are defective and must be replaced.
2. If there is continuous leakage out of Port "5", the problem can be either the valve seals or the cylinder seals. To determine which proceed as follows:
 - a. Disconnect the line between Valve Cylinder Port "4", and the cylinder per Figure 6-2D
 - b. If leakage continues out of Port "5" and/or Cylinder Port "4", the valve seals are defective and must be replaced.
 - c. If there is a leakage out of the line from the cylinder, the cylinder seals are defective and must be replaced.

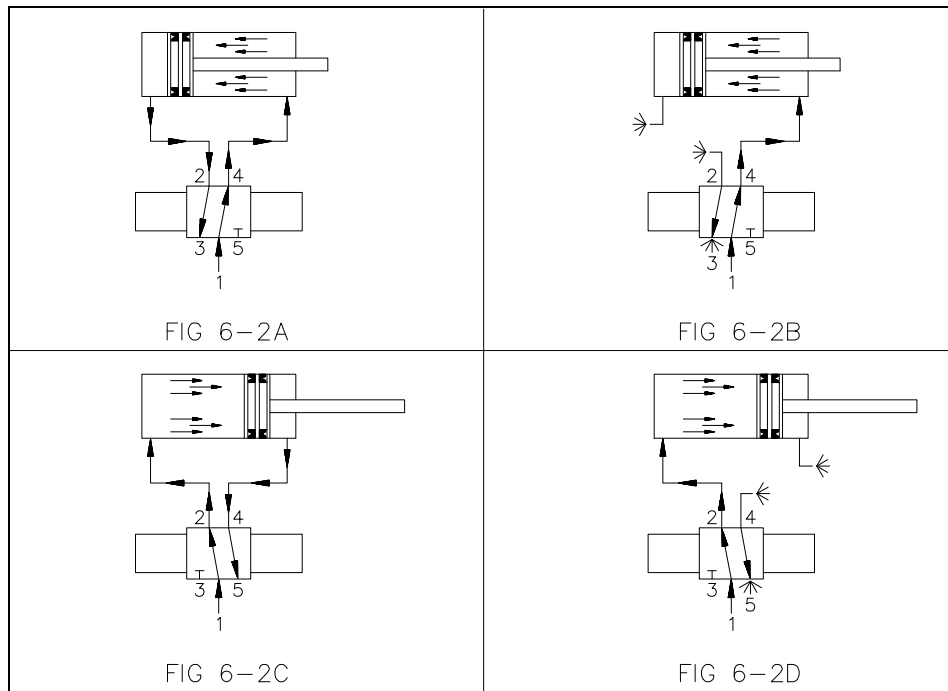

FIGURE 6-2, VALVE VS. CYLINDER LEAK TEST DIAGRAM

VII. REPLACEMENT PARTS

7.1 Scope

The certified drawings list the non-standard components that have been incorporated into the equipment. Intersystems normally stocks non-fabricated parts and non-custom OEM parts. Replacement parts for any other components, including fabricated parts and custom OEM components can be supplied upon request.

7.2 Ordering Parts

Direct parts orders or requests for technical assistance to your sales representative or to:

Intersystems
9575 N 109th Ave
Omaha, NE 68142
Phone 402.330.1500
Fax 402.330.3350

Please have available the MODEL NUMBER, SERIAL NUMBER and CUSTOMER ORDER NUMBER of the equipment in question as well as the location where the sampler is INSTALLED.

7.3 Replacement Parts

The Intersystems sampler is a quality built piece of machinery. As with any machine, parts do wear out and fail. It is Intersystems' recommendation that a small supply of spare parts be kept on hand to cover any minor breakdowns. A separate priced Spare Parts List will be sent identifying the suggested spare parts. It is also necessary to check the certified drawings, which will list any special or custom components utilized on this equipment.

7.4 Repair Kits

The Following chart lists repair kits and parts that are available from Intersystems. These kits are offered as a more economical solution by rebuilding the defective part rather than replacing it. However in some cases the part may be beyond repair and replacement will be necessary.

Product Code	Description
525445	Spool kit for 4-way directional valve (ISI 500 series)
28166	Standard 120 vac valve coil (ISI 500 series)
527134	Rod seal kit for 1-3/8" rod air cylinder (Parker 2MA series)
527855	Piston seal kit for 6" bore air cylinder (Parker 2MA series)
513963	Gauge for filter regulator
524711	Filter element kit for filter regulator (SMC NAW4000 series)
34769	Standard SAE 80W-90 EP Gear Lubricant Oil Quart (Pennzoil 4096)
529601	Optional Synthetic Gear Lubricant Oil Quart (Mobil SHC634)
35527	Limit Switch Contact Block 1 N.O. 1 N.C.

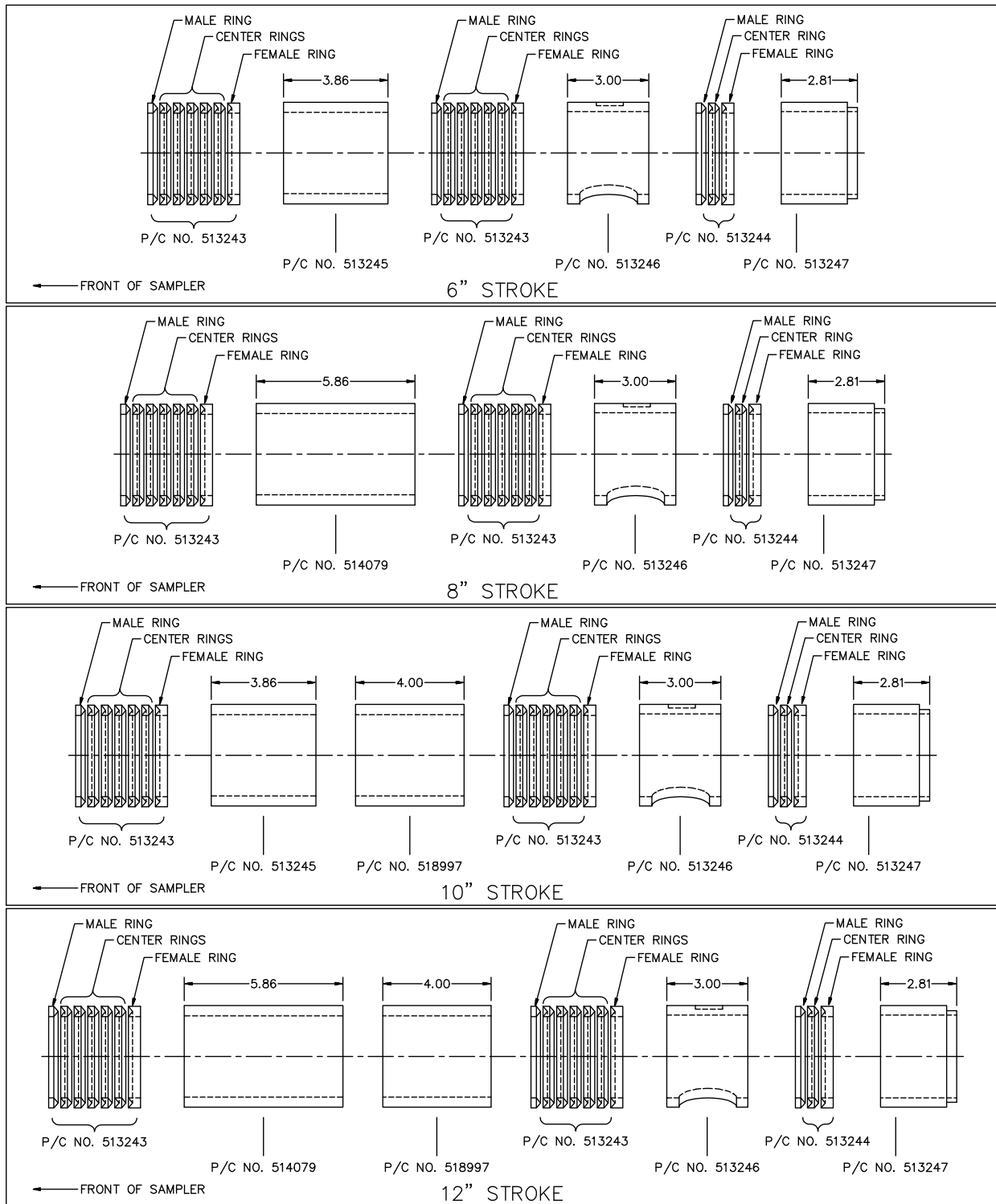

FIGURE 7-1, TEFLON SEAL SPACER ARRANGEMENTS (6", 8", 10" & 12" STROKES)

VIII. WARRANTY

Intersystems reserves the right to make changes in design or in construction of equipment and components without obligation to incorporate such changes in equipment and components previously ordered.

WARRANTY, LIMITATION OF LIABILITY, DISCLAIMER OF IMPLIED WARRANTIES: Intersystems manufactured equipment and components are guaranteed against defects in workmanship or materials for one year from date of shipment. The obligation of Intersystems with respect to any goods is limited to replacement or repair of defective parts and equipment provided those parts are returned, shipping costs prepaid, to Intersystems' factory and provided the product has not been subject to misuse, negligence, or accident, or repaired or altered outside of our factory, or other than by an Authorized Service Representative. This warranty does not cover the replacement of parts inoperative because of wear occasioned by use, the cost of replacing parts by a person other than an Intersystems employee or an Authorized Service Representative, or the adjustment of a product where the product was improperly adjusted by the purchaser. In addition, this warranty does not cover components manufactured by others such as motors, drives, clutches, cylinders, valves, blowers, and the like. On those components the standard Manufacturers' warranty applies. In any event, liability is limited to the purchase price paid, and Intersystems will, under no circumstances, be responsible for special or consequential damages, or for incidental damages.

INTERSYSTEMS NEITHER MAKES NOR AUTHORIZES ANY WARRANTY OTHER THAN AS HEREIN CONTAINED. THIS WARRANTY IS IN LIEU OF ALL OTHER WARRANTIES, EXPRESS OR IMPLIED, INCLUDING THOSE OF MERCHANTABILITY AND FITNESS FOR A PARTICULAR PURPOSE.