

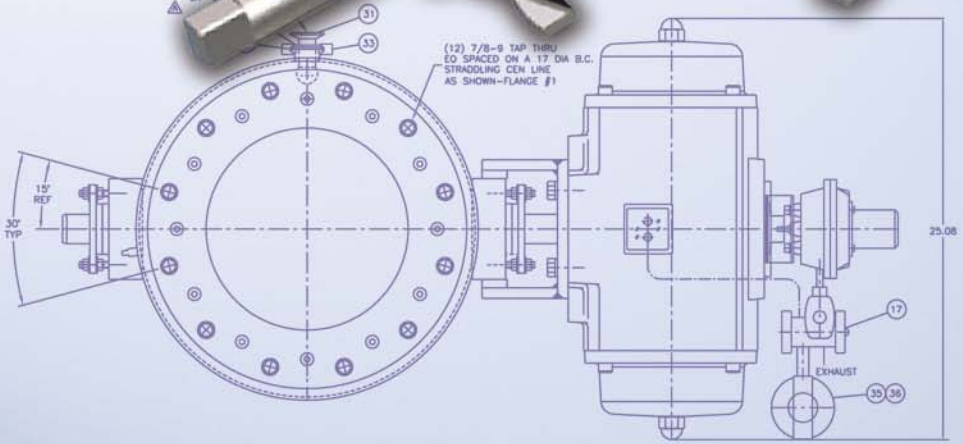

**GEMCO**  
**VALVE**  
COMPANY

# Product Catalog

The Leader in solid-processing Valves

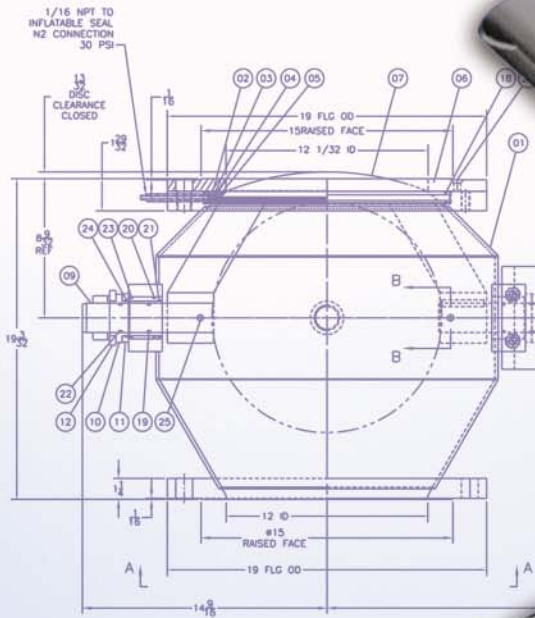
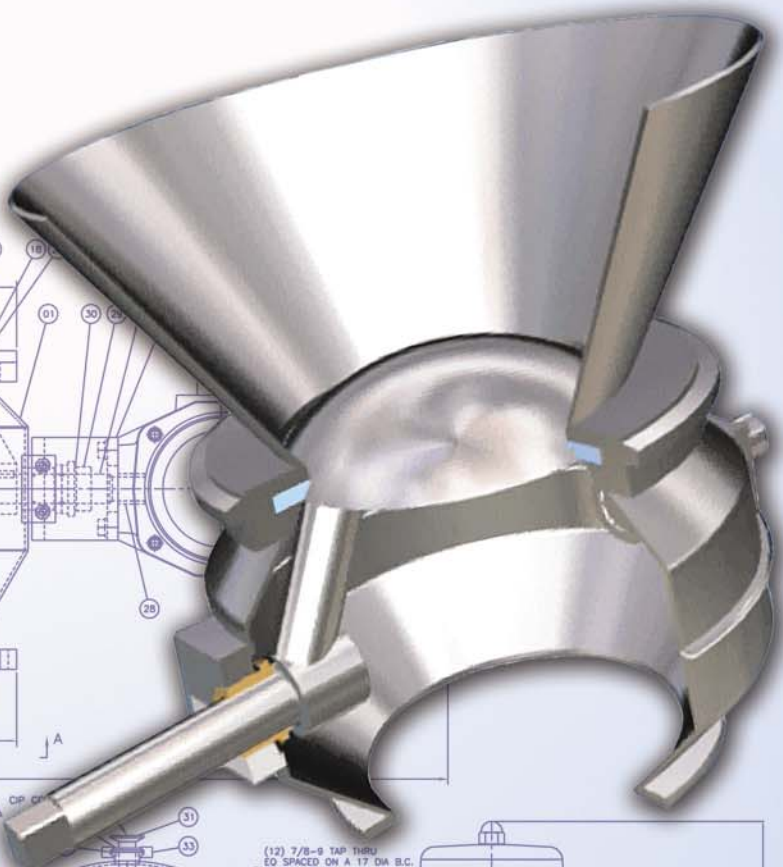

# About Gemco Valve

In the 21st century Gemco Valve remains committed to the same core values of our founders in 19<sup>th</sup> and 20<sup>th</sup> centuries. These ideals of innovation in design, excellence of manufacturing and superior customer service has allowed us to penetrate the global market with the same dedication and support we have established domestically. We continue to research and develop with valve designs and prototype testing for NASA's extended lunar habitation and manned Mars missions.

Our investment in technology has allowed us to not only improve our products, but it has helped us work even more closely with our customers. We now use AutoCAD and SolidsWorks .dwg, .dxf, .pdf and IGES formats to exchange engineering drawings with our clients. Our Web site, training videos, and manuals, along with on-site visits, are ways we support our clients during and after their purchase.

At our plant in Middlesex, NJ, our skilled welders, polishers, CNC machinists and assemblers, who average over 20 years of service, are dedicated to working with the newest manufacturing practices. All our employees work in Total Quality Management teams to promote the best possible service and products.

Gemco Valve continues to meet the ever-increasing challenge of developing new products for containment and durability that will improve worker safety and increase production. We look forward to using emerging technology to help our clients meet the standards of regulatory bodies around the world. Our commitment to developing innovative products will only be matched by our commitment to customer service. Just as we strive to use the latest technologies to improve our manufacturing practices and products, we will continually dedicate ourselves to making our customers our partners.



Gemco's manufacturing facility, Middlesex, NJ

## CONTACT US

By Phone: Domestic: 1-800-OK-GEMCO/1 -800-654-3626

Intl: Access Code +1 732-752-7900 ext. 307

By Fax: 1-732-424-2483 By Email: [sales@gemcovalve.com](mailto:sales@gemcovalve.com)

Our Manufacturing and Home Office:

Gemco Valve Company 301 Smalley Ave. Middlesex, NJ 08846 USA

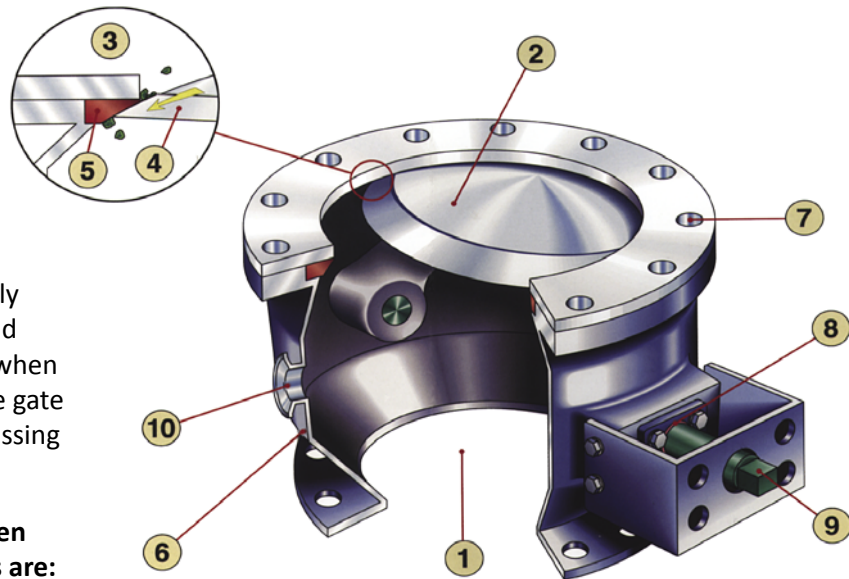

Solids and slurries have completely different characteristics than liquid and gases, so don't be surprised when traditional ball, butterfly and slide gate valves give trouble in solids processing applications.

**The most common problems when handling solids with these valves are:**

1. Material bridging on the center vane of the butterfly resulting in the use of vibrators, ramrods, sledgehammers and other instruments of destruction.
2. Material jamming into the tracks of slide gate valves resulting in sealing surface abrasion with every cycle of the valve.
3. Material packing into the tight cavities of ball valves until the valve ceases or the seat tears apart.

***All Gemco valves address these crucial issues. The P21 model goes even further, easily handling high-performance applications where compliance to international standards, cleanability and containment are required.***

**Top 10 Features of the P21 Gemco Valve**

1. **Full port opening.** Unlike a butterfly valve, the shutoff disc swings completely out of the flow of the material, preventing bridging and promoting mass flow.
2. **No pinch points.** Unlike a ball valve, there are no tight cavities for materials to pack and jam-up the operation.
3. **Self-cleaning sealing area.** Unlike a gate valve, the self-cleaning action wipes the material away from the sealing area instead of jamming abrasives into the sealing track.
4. **Shut-off disc precision machined** from solid plate for high pressure applications.
5. **Seats** available in Teflon or Stellite (both standard).
6. **Body designed,** fabricated and tested to ASME section VIII (pressure vessel) and Section IX (welding procedures) from any weldable alloy. Finishes include mill, #4 polish or #7 mirror finish.
7. **ANSI or DIN bolt** patterns available (both standard).
8. **Exclusive double eccentric bearings** for adjustment of seat disc clearance to achieve an ANSI class VI shut off.
9. **Standard ISO 5211 actuator** mounting allows a greater range of actuator choices.
10. **Optional CIP ports** for spray balls or nozzles available.



**GEMCO  
VALVE**  
C O M P A N Y

# P21 Valve

High performance spherical disc valve

The **P21 High Performance Spherical Disc Valve** is designed to meet tomorrow's demanding requirements for containment of solids, powders and slurries. Engineered for pressure assisted sealing from full vacuum to 150 PSI. GEMCO valves use a spherical disc which moves across the seat wiping material away from the sealing area. This self wiping action eliminates pinch points - the source of most valve wear. The P21 is offered with standard ANSI or DIN flanges and ISO actuator mounting.

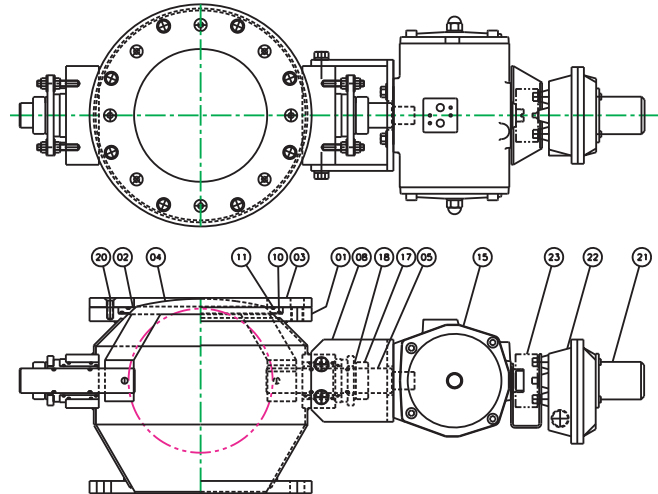

# T Valve

For heavy duty service

The **Type T Valve** is designed for heavy-duty service. It is typically used for slurries, abrasives, and dense materials. The T valve is available in 316 stainless steel, Cast Iron, Aluminum as standard and can be fabricated from any weldable alloy with the full range of sanitary finishes. Options include high temperature or pressure (3 bar) designs. T valves are commonly used for charging and discharging hoppers, tanks, silos, conveying systems, and weighing systems.

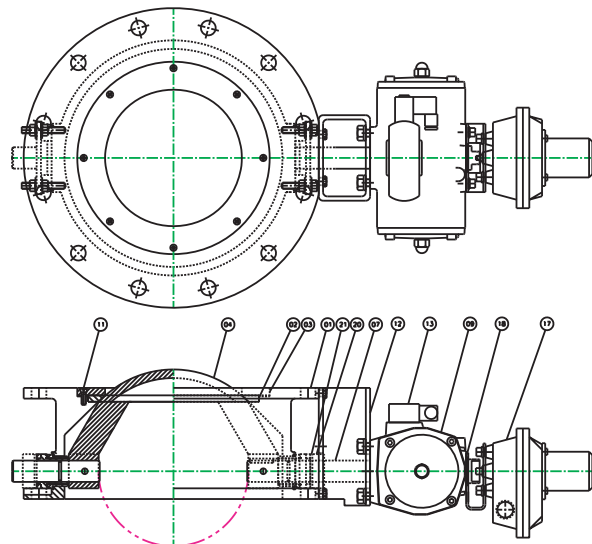



**GEMCO  
VALVE**  
C O M P A N Y

# TLD Valve

Versatile and lightweight

The versatile and lightweight Type **TLD Valve** is typically used for processing less dense materials such as foods and pharmaceuticals and on rotating and mobile equipment where weight is a concern. It is available in a range of cast and weldable alloys including 316 stainless steel and Hastelloy. The sanitary version of the TLD Valve has full interior and exterior polishes. ANSI and DIN drilling patterns are offered in addition to the Gemco standard pattern. The valve is offered for dust tight, full vacuum and low-pressure (1 bar) services. Common installations of the TLD Valve include inlet/outlet valves on rotating or stationary blenders and Intermediate Bulk Containers.

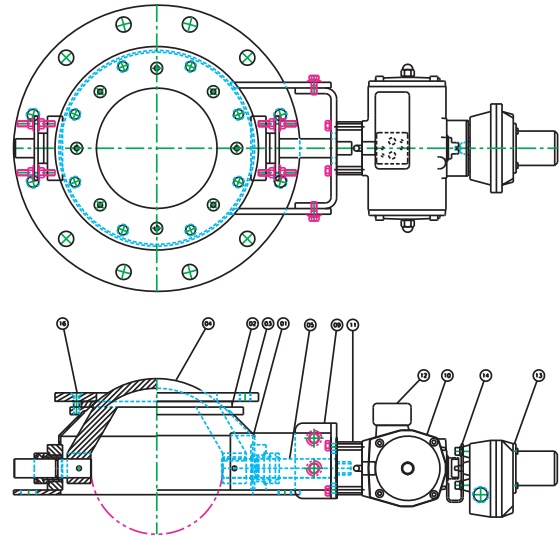

## Airlock

For flow of material between two atmospheres

Gemco **Airlocks** are designed to control the flow of material between two atmospheres or pressures. They typically consist of two standard Type T Valves connected by an intermediate chamber and are often used instead of rotary feeders, which are prone to high maintenance and leakage of material and gases. Normal cycling varies from one to three times per minute. Slower cycling is possible and nominal material flows of one half to ten cubic feet per cycle are available. Chamber purge, sight glasses, clean-out ports, and automatic cycling controls are among the custom engineered options available.

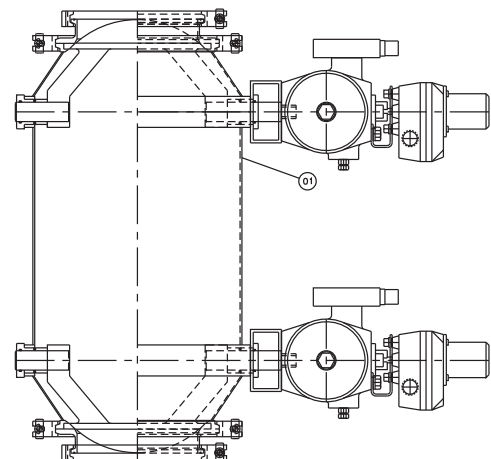



**GEMCO  
VALVE**  
COMPANY

# Flush Mounted Valve

Allows for minimizing or eliminating “dead space”

**Flush mounting** is available as an engineered option for most Gemco Valves. Flush mounting allows for minimizing or eliminating “dead space” - the area of a processor where the product is not mixed. We provide a pad or weld neck custom manufactured to suit a specific tank radius. This design with our standard spherical disc reduces dead space. To eliminate dead space we can also contour the spherical disc. This customization is first modeled in 3D then manufactured on CNC machining centers.

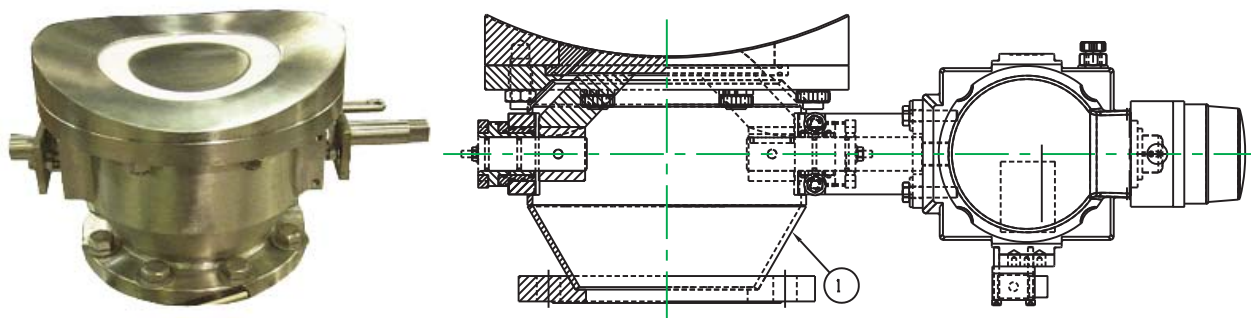

# K Valve

Sanitary K Valve is designed to USDA and FDA guidelines

The **sanitary K Valve** is designed to USDA and FDA guidelines eliminating threads, keyways and crevices. The split body design means the K-valve can be completely disassembled with simple hand tools, allowing quick and easy inspection and cleaning. It is used for charging/discharging or in-line with standard quick clamps allowing fast installation and removal. The K valve is offered in sizes from 3” to 8” (75 to 200 mm) in practically any weldable alloy with the option of #4 satin or #7 mirror finish. Pressure and vacuum applications are engineered to order. Commonly used in the food, pharmaceutical and nutraceutical industries or anywhere where cleanability and quick change over is required.

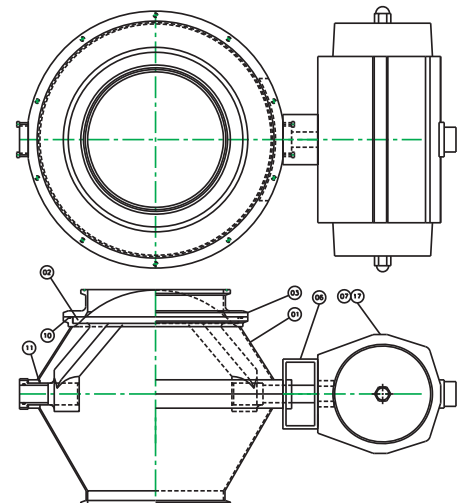



**GEMCO  
VALVE**  
C O M P A N Y

# Sani Valve

For rapid disassembly, cleaning, and assembly

Gemco **Sani Valves** are designed for rapid disassembly, cleaning, and assembly. It includes a Patent-pending locking system and is designed to FDA and USDA guidelines.

The unique simplified design eliminates all internal keyways, threads, and crevices and replaces tedious fasteners with quick clamps.

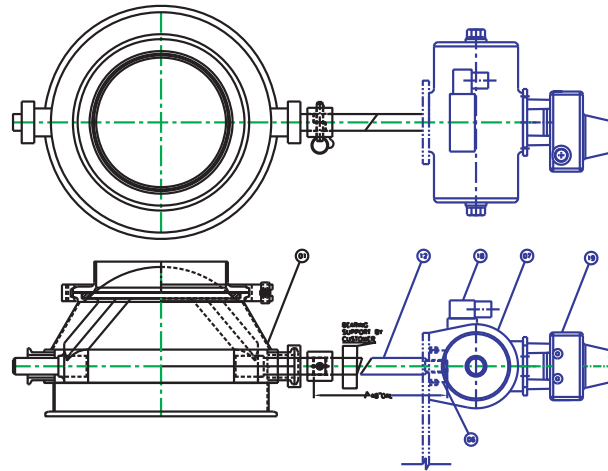

# SB Valve

For ultra low profile

When ultra low profile is required we offer the **SB Sanitary Butterfly Valve**. Compliant with the USDA 3A requirements for manual cleaned butterfly valves for handling dry powders. The valve dismantles by hand in minutes for quick inspection and cleaning. Manufactured in the US from 316L Stainless Steel and FDA Silicone seals the valve is offered in #4 satin or #7 mirror polish with manual or air operators. Standard and engineered options such as weld necks and Tri-clamps are also offered. Many sizes are stocked or are available with short lead times.

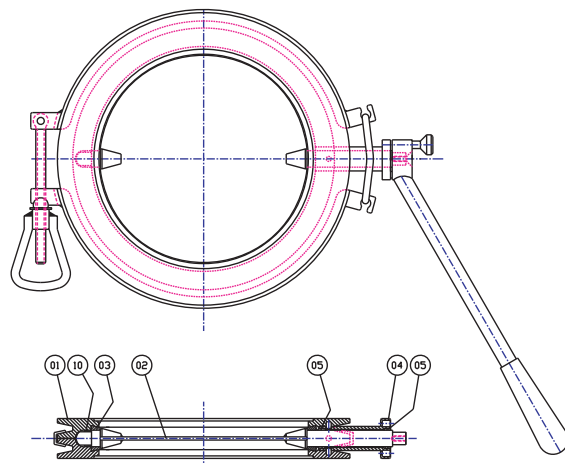



# D2 Diverter Valve

'Y' junction valve

The **D-2 Diverter Valve** places the Gemco Spherical Disc Valve in a 'Y' junction that allows the valve to select a product feed from one of the two inputs, or to direct one incoming stream of material to either of the two outlets. The standard D-2 valve is constructed of 316 stainless steel, but it can be made from any weldable alloy. The two ports can be positioned at 30 degrees, 45 degrees, or 60 degrees off the center-line of the third port. Typical Diverter applications take advantage of its rugged design and its optional sanitary version in uses varying from rock crushers to food processing.

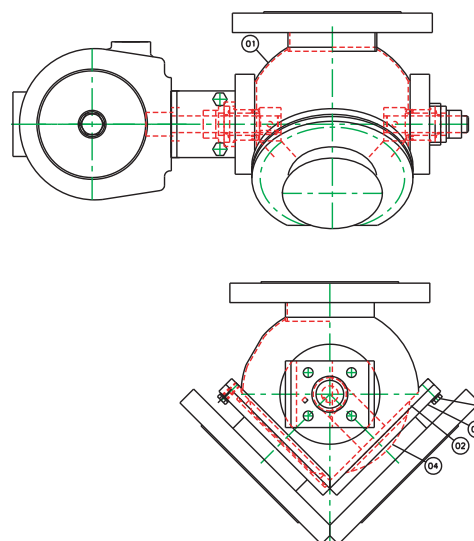

# Cone Valve

Match the discharge angle

Gemco **Cone valves** are also called **cover valves**, as both are manufactured to match the discharge angle of a hopper or tank. Cone valves are usually bolted or welded to parent equipment, while cover valves are usually hinged to the tank so they open like a cover allowing access to the vessel for inspection, cleaning and maintenance. Typical sizes are 8" and 10" with 45° or 60° cone angles.

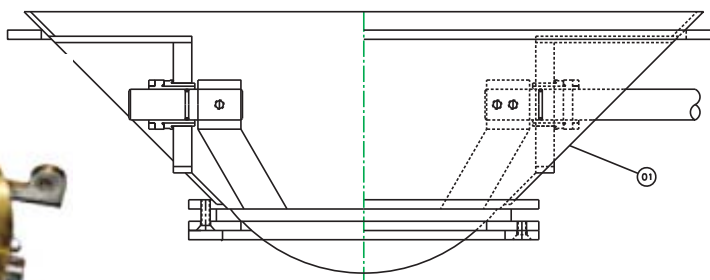



**GEMCO  
VALVE**  
COMPANY

# GMC Valve

Economic, reliable

Dating back to the 1960s the **Gemco GMC valve** is an economic, reliable, dust-tight shut off valve for non-sanitary applications. It is designed for material flow in one direction and is usually used for discharging tanks and hoppers. Available in a range of weldable alloys in sizes from 6" through 16" with manual, chain, gear or air operators.

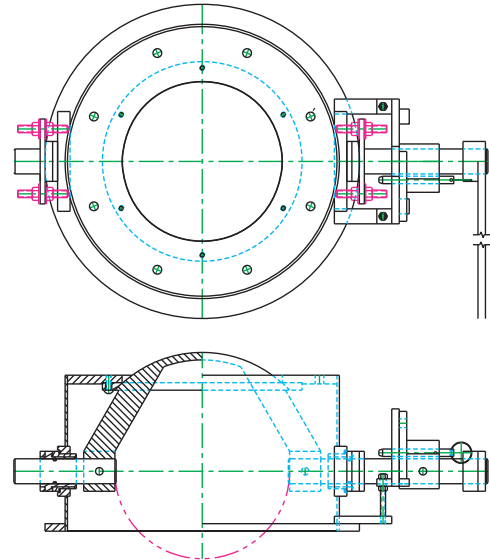

## Retractable Sleeve

For dustless transfer of solids

The pneumatically operated Gemco **Retractable Sleeves** are designed for the dustless transfer of solids from one processor to another. These Retractable sleeves are available in telescoping rigid designs (usually stainless steel), or flexible boots, (usually white Neoprene). The telescoping models are used for one-way flow and the flexible models are used for bi-directional flow. The two pneumatic cylinders of the Retractable sleeve can be controlled locally, remotely or by automatic sequencing. Our sleeves are available in a range of finishes and coatings with a variety of stroke lengths and mounting configurations.

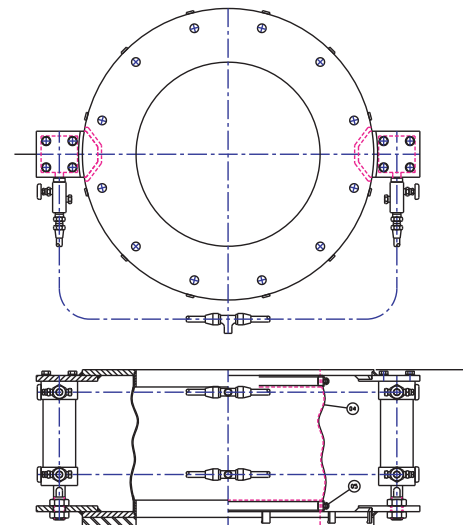
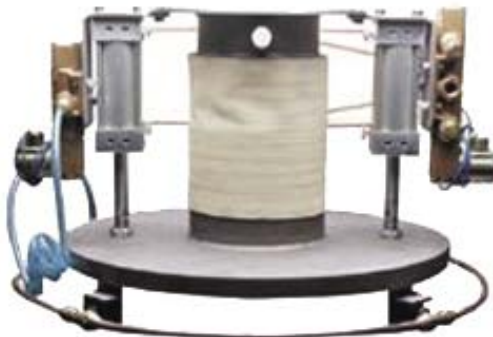



**GEMCO  
VALVE**  
C O M P A N Y

# Choosing The Right Valve

Some of the factors to consider when choosing a Gemco Valve are:

- Material of construction
- Seat material
- Cleanability
- Weight
- Mounting arrangements
- Actuation
- Flow Control

## Material of construction

The powders and/or solvents to be processed will dictate the product contact material. Cast Iron, Carbon Steel, and Aluminum can be used for many industrial applications. Corrosive processes will call for the use of Stainless Steel, and in some cases material laden with solvents or other corrosives will justify the extra expense of using Hastelloy or other high nickel alloy to prolong valve life.

For Stainless Steel valves of welded construction, 316L grade is preferred, as carbon content prevents carbon precipitation from welded joints.

## Seat material

Very abrasive material will tend to dictate using metal seats versus the more commonly used reinforced Teflon seats. The metal seal will give longer life and can be used at higher temperatures than Teflon but the shut-off sealing is limited to dust tight, ANSI class IV or ANSI class V. Reinforced Teflon can be used up to 450 degrees F (230 C), and provide pressure assisted Class VI shut-off. For bi-directional Class VI shut-off, an Inflatable seat is typically required.

## Cleanability

The sanitary requirements of the process will govern the surface finishes and other sanitary options. We define our finishes as follows:

No surface finish (Ra) specified. Sometimes referred to as "mill finish" or "as cast". Fabricated valves will only have the internal welds ground smooth and flush. Commonly used in general industrial applications where cross contamination or cleanability are not a concern.

#2 finish - Ra 33 to 65 micro inch - 150 to 180 grit. Also referred to as "buffed, blended or uniform appearance finish". Often specified for the outside of equipment that will be washed down.

#4 polish - Ra 16 to 32 micro inch - 180 to 240 grit. All fabrication and handling marks removed. Surface is buffed to a uniform satin finish. The #4 polish is typical for the interior of equipment that needs to be cleaned between batches to prevent cross contamination.

#7 polish - Ra 10 to 15 micro inch - 240 to 320 grit. All surface imperfections are repaired. Often referred to as "pit free" and "mirror finish". Used for high purity applications such as processing potent pharmaceutical actives. Also used for products that tend to adhere to surfaces.

For automatic cleaning, spray balls or jets should be considered. Another option is a valve that can be dismantled by hand for inspection and cleaning. For safety reasons the size of such valves are typically limited to an 8" port diameter due to the weight of individual components.

# Choosing The Right Valve

continued

## Weight

The weight of a valve is especially important for mobile or rotating equipment. High performance and heavy-duty models can weigh four times as much as its regular-duty counterpart. Dust tight, full vacuum, and 1 bar service, is considered to be regular duty service. 90 PSI (6 bar) to 150 PSI (10 bar) is high performance. An 8-inch manually operated regular duty valve can weigh 55 lbs (25Kg), versus nearly 200 lbs. (90Kg) for an 8" high performance model.

## Mounting arrangements

The typical ANSI 150 # and DIN drilling is used as an industry standard for heavy duty and high performance models. Quick clamps can be used for applications up to 30 PSI (2 bar) and port sizes up to 8".

Some valves will include blind tapped holes, which may be a problem if the valve is mating with existing blind tapped holes. Another option is to choose oversized flanges, which allows for through holes. For regular duty service valves, ANSI and DIN bolting can be overkill and alternative bolting patterns are available.

## Actuation

As with other quarter turn valves; levers, gear drives or chain operators are available. Pneumatic and hydraulic, operators are available in double acting or fail-safe modes. Pneumatic operation should be the first choice for price, reliability, and speed. When handling solids a higher factor of safety is used to calculate seat torque requirements. The factor is typically 1.5 instead of the 1.25 used for liquid and gas valve calculations.

For solids that "set-up" or harden oversized actuators and specially designed discs that can break through the hardened cake are used. Actuators are typically sized for 80-PSI (5.3 bar) pressure. If the available supply air pressure is dependably higher (100 to 120 PSI) or lower (40 to 60 PSI), this will factor in the sizing of the actuator.

For fail-safe operation, spring return actuators are the norm. When a spring return type actuator is used, it is oversized to compensate for the spring as well as the unseating, run, and seating torque required for valve operation. This can lead to weight and space problems as well as extra cost. An alternate fail-safe option is to use a double acting actuator with a pneumatic accumulator sufficiently sized to close the valve. If there is a loss of pneumatic pressure, a pressure switch activates the accumulator and operates the valve.

## Flow Control

Fast acting (1 to 5 seconds), quarter turn valves are ideal for flow control of solids. A pneumatic (3 to 15 PSI) or electro-pneumatic (4 to 20 milliampere) positioner can take a signal from a manual adjusted pressure regulator, or from a computer controller. The pneumatic positioner is often used in manually operated filling stations, while the electro-pneumatic positioner is typical for automatic loss-in-weight systems.

## Summary

Choosing the best valve for your powder application will give better performance, lower maintenance costs and better product quality resulting in lower equipment life cycle costs. For more information please visit our web site at <http://www.gemcovalve.com> or call Doug Krok at 800 OK GEMCO/800-654-3626 extension 307, International +1 732-752-7900 extension 307.



**GEMCO  
VALVE**  
C O M P A N Y



**All Gemco Valves handle high-performance applications  
where compliance to international standards, cleanliness  
and containment are required.**



## **Gemco Valve Company**

301 Smalley Ave., Middlesex, NJ 08846 USA

Domestic: 800-OK-GEMCO/800-654-3626 Fax: 732-424-2483

International: +1 732-752-7900 extension 307

**Web Site: <http://www.gemcovalve.com>**